Dr. coffee M12 Service Manual

(Version: V01)



❖ Applied Model:

M12 Series

Due to product upgrades, there may be differences between the pictures and the actual products please refer to real object.

1 Contents

1	CONTENTS	2
2	SAFETY INSTRUCTIONS	7
2.1	Safty Tips	7
2.1.1	Consumer Risky	7
2.1.2	Machine Risky	8
3	STRUCTURE INTRODUCTION	9
3.1	Overview.....	9
3.2	Internal Components Overview	10
4	SCHEMATIC CIRCUIT	12
4.1	M12 Main Control Board Circuit	12
4.2	M12 Power Board Circuit	13
5	TECHNICAL DATA	14
5.1.1	Capacity	14
5.1.2	Technical Sheet	14
6	SCREENSHOT DESCRIPTION	15
6.1	Drinks Home Screen.....	15
6.2	Language Setting.....	15
6.3	Menu	16
6.3.1	Brewer Rinse	16
6.3.2	Milk Rinse	16
6.3.3	One-Button Maintenance	17
6.3.4	Service Menu	18
6.3.5	Wipe Protect.....	18
6.3.6	Information.....	19
6.3.7	Power Off.....	20
7	SERVICE MENU.....	21
7.1	Drinks Setting.....	21
7.1.1	Drinks Position Changing	22
7.1.2	Delete Drinks	22
7.1.3	Drinks Parameters setting	23
7.1.3.1	Drink Name	23
7.1.3.2	Change to	23
7.1.3.3	Picture Changing	23
7.1.3.4	Payment.....	24
7.1.3.5	Lock	24
7.1.3.6	Small Cup.....	24
7.1.3.7	Medium Cup	24
7.1.3.8	Large Cup.....	24

7.1.3.9	Cup Type Selection.....	24
7.1.3.10	Grounds.....	24
7.1.3.11	Pre-brewing(s).....	25
7.1.3.12	Coffee (ml).....	25
7.1.3.13	Cold water(ml).....	25
7.1.3.14	Circle-index.....	25
7.1.3.15	Brew Pressure.....	25
7.1.3.16	Hot water (ml).....	25
7.1.3.17	Milk (s).....	25
7.1.3.18	Milk Foam (s).....	25
7.1.3.19	Waiting (s).....	25
7.1.3.20	Extraction method.....	25
7.1.3.21	Temperature class.....	25
7.1.3.22	Order.....	25
7.1.4	Create New Drinks.....	26
7.2	Maintenance.....	27
7.2.1	Brewer Deep Clean.....	28
7.2.2	Milk Deep Clean.....	28
7.2.3	Descaling.....	28
7.2.4	Water Draining.....	28
7.2.5	Filter.....	28
7.3	Machine Setting.....	30
7.3.1	Maintenance Setting.....	30
7.3.2	Time/Date.....	31
7.3.3	Unit.....	31
7.3.4	Password.....	32
7.3.5	RGB Setting.....	32
7.3.6	Temperature Control Setting.....	33
7.3.7	Network Setting.....	33
7.3.8	Auto Power On/ Off.....	34
7.3.9	ECO Mode.....	34
7.3.10	Grid Connection.....	35
7.4	Eng. Setting.....	36
7.4.1	Grinding Calibration.....	36
7.4.2	Grinding Index.....	36
7.4.3	Water Supply.....	37
7.4.4	Factory Setting.....	37
7.4.5	Business Setting.....	38
7.4.5.1	Payment Settings.....	38
7.4.5.2	Mode Selection.....	38
7.4.5.3	Monetary Unit.....	38
7.4.5.4	LOGO Setting.....	39
7.4.5.5	Startup Picture Setting.....	39
7.4.5.6	Screen Saver Picture Setting.....	39

7.4.5.7	Enter screen saver setting (min)	39
7.4.5.8	Exit screen saver setting (min)	40
7.4.5.9	Screensaver interval time(s).....	40
7.4.5.10	Advertising Mode	40
7.4.6	Parameters Import & Export	41
7.4.6.1	Drinks Param.....	41
7.4.6.2	Maintenance Param	41
7.4.6.3	Machine Param	41
7.4.6.4	Engineer Param	41
7.4.6.5	Daily Record.....	41
7.4.7	Program Update.....	42
7.4.7.1	Current Version.....	42
7.4.7.2	Remote Latest Version	42
7.4.7.3	Online Update.....	42
7.4.7.4	USB Drive Update	42
7.4.8	Function Switch	43
8	WARNING	44
8.1	Warning with Tips in the Screen	44
8.1.1	Water Tank Is Empty	44
8.1.2	Grounds Container Is Full Up	44
8.1.3	Bean Hopper Empty.....	44
8.1.4	Drip Tray Is Not In Place	45
8.1.5	Drip Tray Is Full Up	45
8.1.6	Waste Water Bucket is Full.....	45
8.1.7	Coffee Thermo Block Over-heated.....	46
8.1.8	Steam Thermo Block Over-heated	46
8.1.9	Coffee Thermo Block Temp. Is Too Low.....	46
8.1.10	Steam Thermo Block is Too Low.....	47
8.1.11	The Hot Water Thermo Block is Too Low	47
8.1.12	Environment Temp. Is Too Low	47
8.1.13	Lack of Water.....	48
8.1.14	Pressure Overloaded	48
8.1.15	Grinder Calibration	48
8.1.16	Brewer Check Up	49
8.1.17	Brewer Washing Required.....	49
8.1.18	Milk Deep Clean.....	49
8.1.19	Descaling Required	50
8.1.20	No Network	50
9	TROUBLE SHOOTING	51
9.1	Error with Tips in the Screen	51
9.1.1	Water Supply Error.....	51
9.1.2	Steam Thermo Block Water Supply Error.....	51

9.1.3	Grinder Error.....	51
9.1.4	Brewer System Error.....	51
9.1.5	HMI Communication Error.....	52
9.1.6	Hot Water NTC Error.....	52
9.1.7	Steam Thermo Block NTC Error.....	52
9.1.8	Coffee Thermo Block Heating Overtime.....	53
9.1.9	Steam Thermo Block Heating Overtime.....	53
9.1.10	Hot Water Thermo Block Heating Overtime.....	53
9.2	Error without Tips in the Screen.....	54
9.2.1	Fail to switching on.....	54
9.2.2	No Milk.....	54
9.2.3	No Milk Foam, Warm Milk Only.....	54
9.2.4	No Coffee.....	55
9.2.5	Software System Crashed.....	55
9.2.6	Leaking.....	55
10	DISASSEMBLY & ASSEMBLY.....	56
10.1	Tools.....	56
10.2	General Disassembly.....	57
10.2.1	Disassemble Exterior Parts.....	57
10.2.1.1	Disassemble Upper Panel.....	57
10.2.1.2	Disassemble Rear Panel.....	58
10.2.1.3	Disassemble Left and Right Panel.....	58
10.2.2	Disassemble Brewer Unit.....	59
10.2.3	Disassemble Pressure Releasing Valve.....	60
10.2.4	Disassemble Drive Motor Group.....	61
10.2.5	Disassemble Pinch Valve.....	62
10.2.6	Disassemble Magnetic Valve Group.....	63
10.2.7	Disassemble Pump Group.....	64
10.2.8	Disassemble Flow Meter.....	65
10.2.9	Disassemble Water Inlet Valve.....	65
10.2.10	Disassemble Grinder Group.....	66
10.2.11	Disassemble Thermo Block.....	67
10.2.12	Disassemble Water Inlet Valve.....	68
10.2.13	Disassemble Power PCB.....	69
10.2.14	Disassemble Cntrol Board.....	69
10.2.15	Disassemble Front Panel Group.....	70
11	MAINTENANCE.....	72
11.1	Milk Frother Cleaning.....	72
11.1.1	Method for Disassembling Milk Frother.....	72
11.1.2	Method for Installing Milk Frother.....	72
11.2	Milk Pipe Cleaning.....	73
11.2.1	Method of Milk Pipe Dissembling.....	73

11.2.2	Method of Milk pipe connection.....	73
12	DAILY USE AND MAINTENANCE CONSIDERATIONS	74

2 Safety Instructions

2.1 Safety Tips

2.1.1 Consumer Risky

 **Caution** You may get hurt if instructions are not well followed.

Do follow below points:

- ❖ Do read the instructions carefully before using;
- ❖ Do not use if the machine is broken or damaged;
- ❖ Changing the internal devices is not permitted;
- ❖ Touching the high temperature components is not permitted;
- ❖ His equipment can be used by children of 8 years and above, and by persons with reduced physical, sensory or mental abilities or of a lesser level of experience and knowledge when they are supervised or have been trained in the safe use of equipment;
- ❖ Take care of the children. Children are not permitted to play with the equipment;
- ❖ Children are not permitted to clean and maintenance machines;
- ❖ Machine is installed at obvious site;
- ❖ Self-service use and operation should be supervised by trained personnel to ensure compliance with maintenance regulations and to resolve usage issues at any time;
- ❖ Beans hopper only for beans, powder hopper only for powder, and manual outlet only for cleaning tablet.

 **Warning Electric Shocks** Improper use of electrical equipment can cause electric shock.

Do follow below points:

- ❖ Work on electrical equipment can only be carried out by electrical professionals;
- ❖ The machine must be connected with fuse-connection circuit (connection by selective protection);
- ❖ Observe the corresponding low voltage and local and regional safety regulations;
- ❖ The connection must obey the regulation to avoid the electronic;
- ❖ The voltage must be matched with rating plate;
- ❖ Do not touch live parts;
- ❖ Power off while maintenance, disconnected the machine;
- ❖ Cable replaced only permitted to the trained professional technician.

 **Warning** Drinks with additives or residues may cause allergies.

Do follow below points:

- ❖ In self-service, check for possible allergenic products listed on the coffee machine;
- ❖ In self-service, check for possible allergenic products with professional person.

 **Warning** There is risky of getting poison by touching cleaning powders.

Do follow below points:

- ❖ Always keep cleaning tablets put of children and un-authorized person ;
- ❖ Do not eating or drinking cleaning products ;
- ❖ Do not mix cleaning products with other chemicals ;
- ❖ Do not add cleaning products in milk container ;
- ❖ Do not add cleaning products in the water tank ;
- ❖ Cleaning products and decalcifying agent must be used under instructions (follow the label) ;
- ❖ Do not eat or drink during using cleaning products ;
- ❖ Good ventilation must be ensured when using cleaning products ;
- ❖ Do Wear gloves ;
- ❖ Wash hands immediately after using cleaning products.

⚠ Caution Scald It is risky to get burned, keep hands far away from steam outlet.

⚠ Caution Scald High temperature on the outlet and brewing system, only rinse the brewing system after cooling down.

⚠ Caution Crushing It is risky of being crushed by touching any active parts. Do not put your hands into bean hopper, powder container and brewing system during working.

2.1.2 Machine Risky

⚠ Warning The machine may be cause impurities and damages if not installed properly.

Do follow below points:

- ❖ If the hygiene is less than 5° dHK, please install water filter otherwise the machine may be damaged;
- ❖ Turn off the tap water (machines is installed with tap water connection), then turn off the switch or plug off;
- ❖ Observe the corresponding low voltage and local regional safety regulations;
- ❖ If machine is lack of water do not switch on. Otherwise the boiler will be damaged;
- ❖ Dr. coffee suggested to install check valve in the water tube, in case of the water leakage by the tube crack;
- ❖ If the machine stops using for a while, deep cleaning must be done before making coffee;
- ❖ Prevent coffee machines from being affected by bad weather;
- ❖ Check errors with technicians only ;
- ❖ Please use original Dr. coffee accessories;
- ❖ Please contact with after sale service team to do replacement if find damage on the surface;
- ❖ Washing the machine with water or steam cleaning products is not permitted;
- ❖ Do not place the machine in the location which may jet by water;
- ❖ Beans hopper only for beans only, powder hopper only for instant powder only, manual outlet only for tablets;
- ❖ Frozen dry coffee is not permitted, otherwise the brewer will be stick;
- ❖ If delivered under 10°C, before switch on the coffee machine must be placed three hours for room temperature recovering after shipment, otherwise it may lead to short circuit hazard or damage to electrical components;
- ❖ New hose kit (drinking water/waste water hose) supplied with the machine should be used, and do not use old hoses.

3 Structure Introduction

3.1 Overview

(M12 Plus Front Side)



(M12 Plus Back Side)



3.2 Internal Components Overview

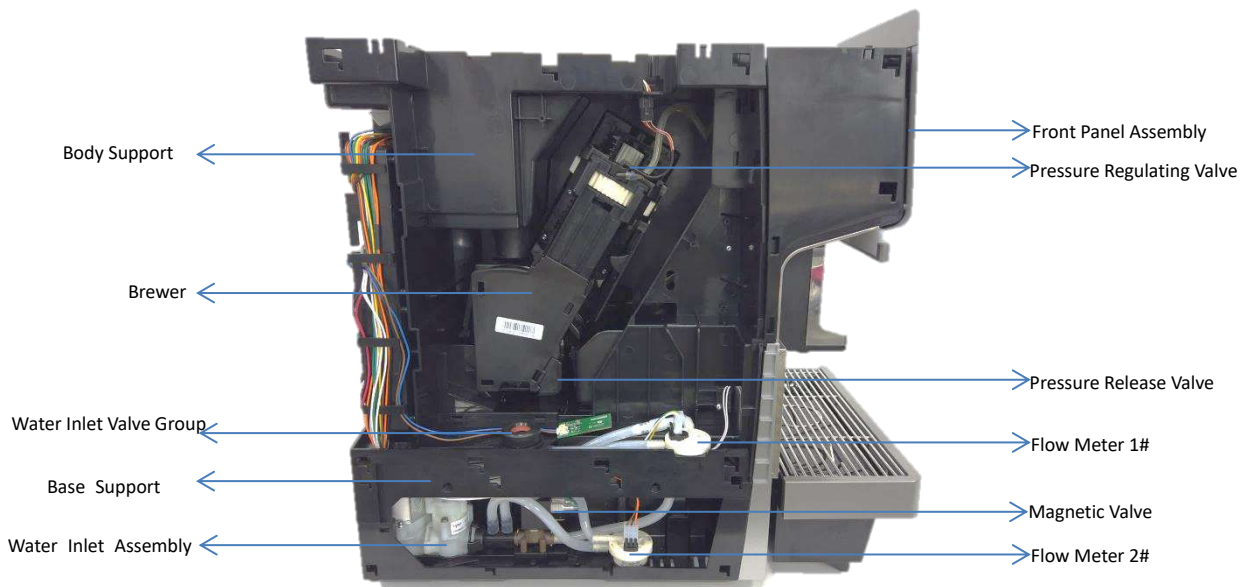
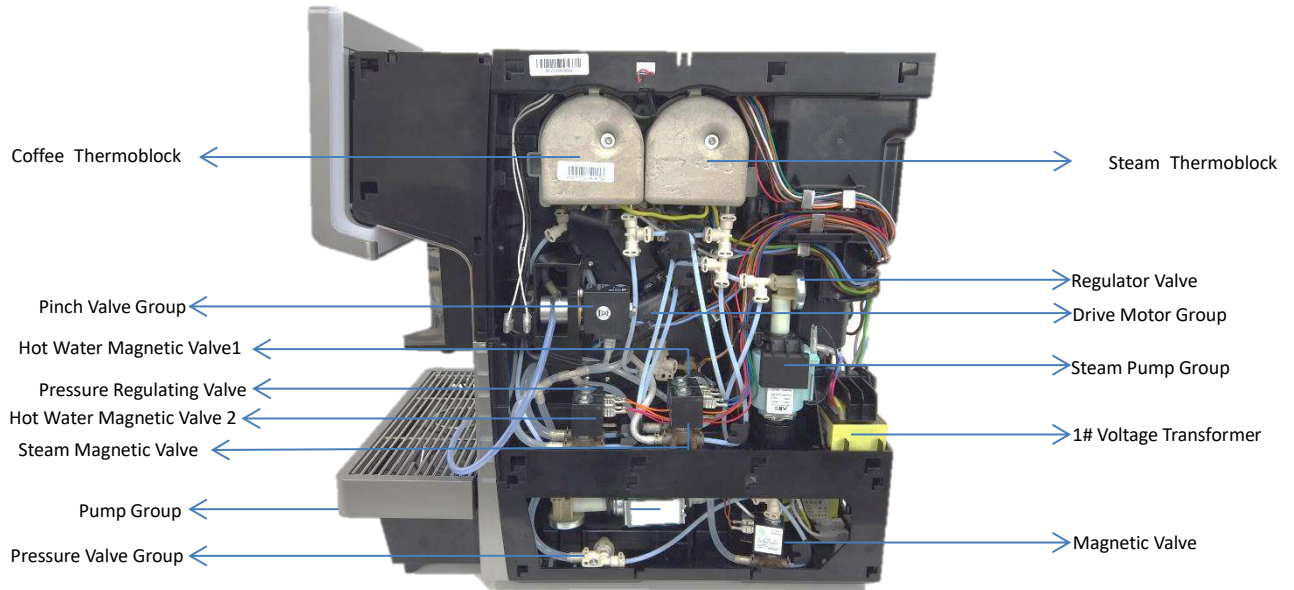

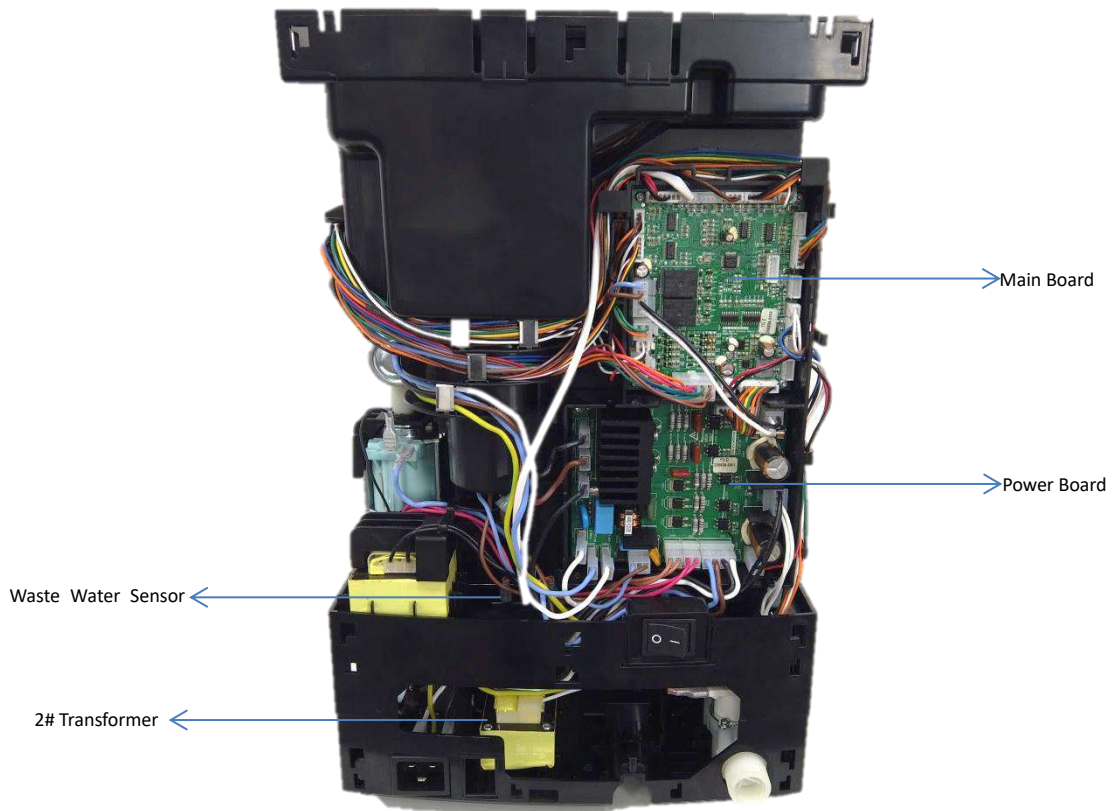
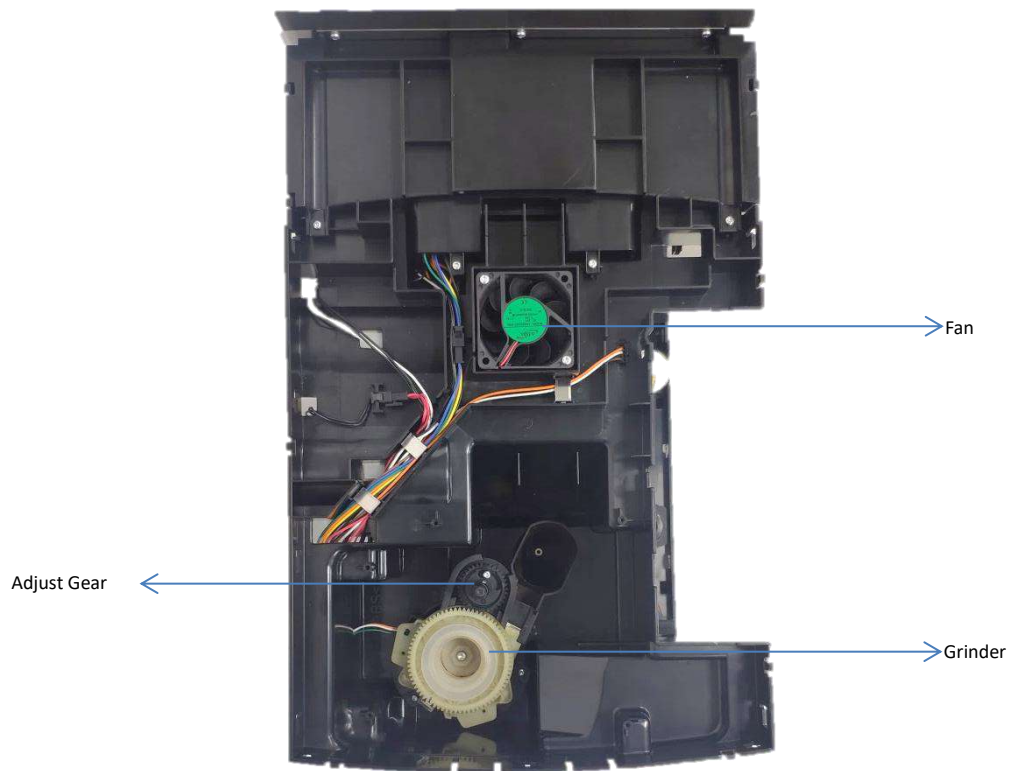

4 Schematic Circuit

4.1 M12 Main control board circuit

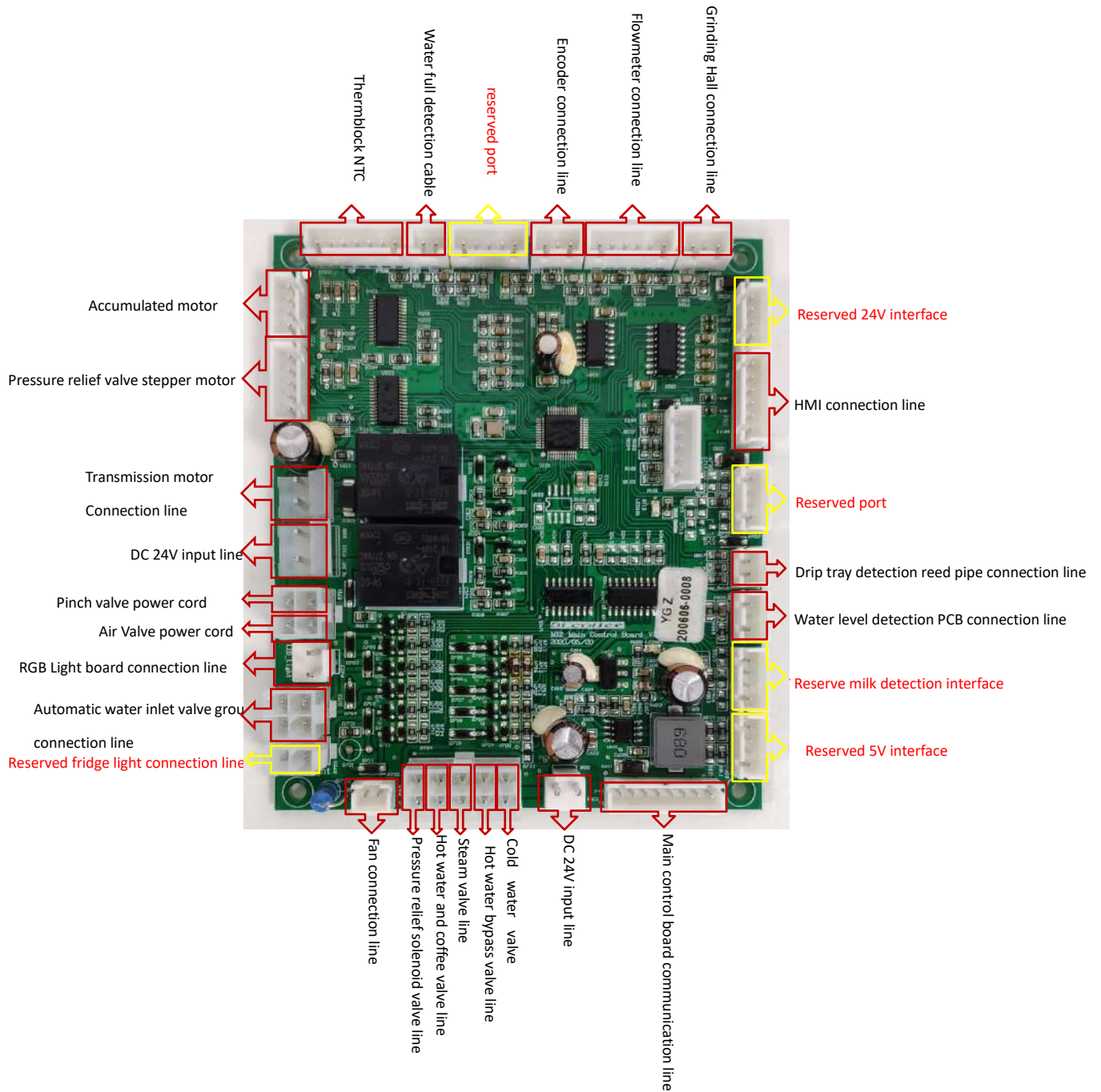

4.2 M12 Power Board Circuit

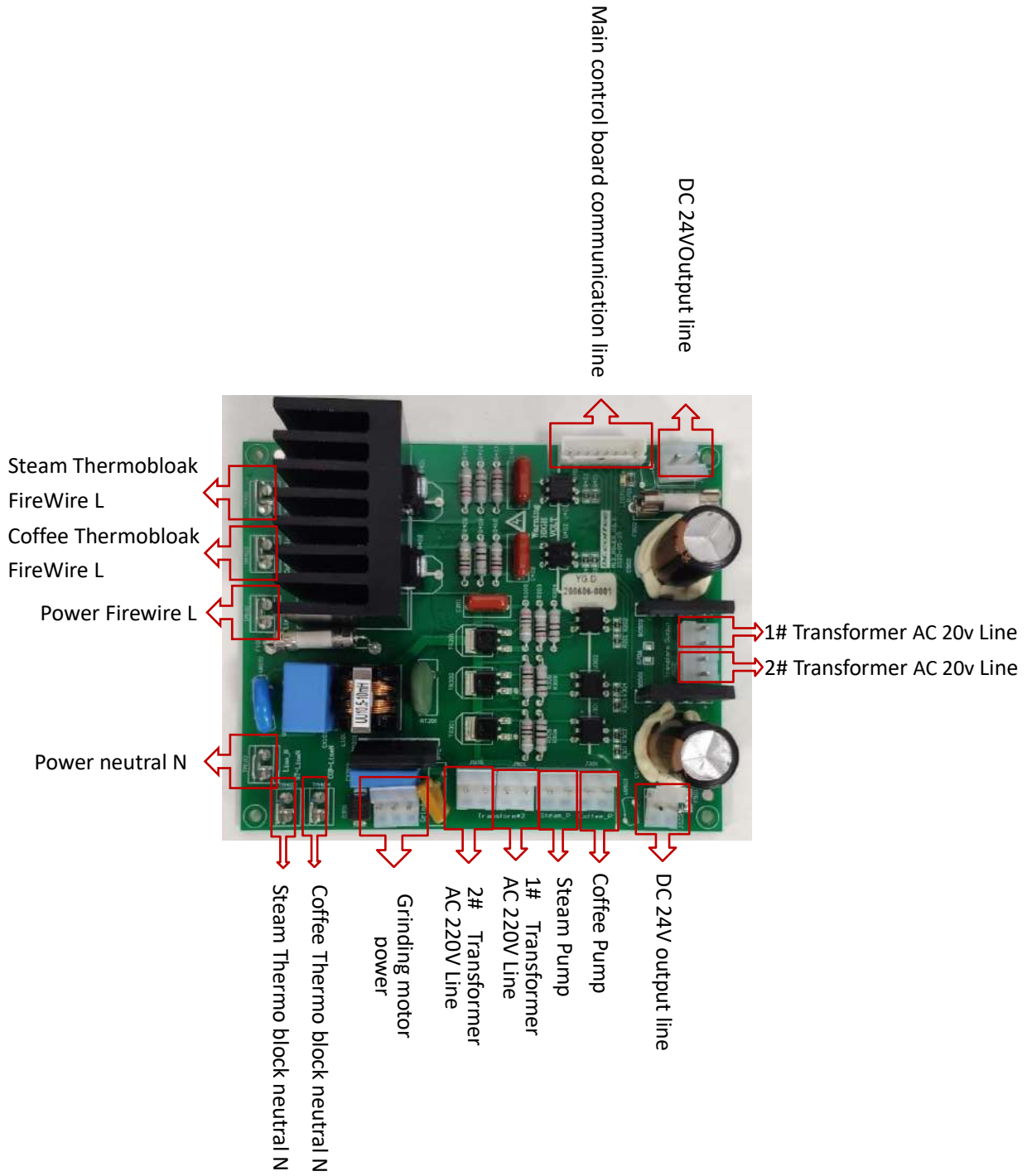

5 Technical Data

5.1.1 Capacity

Hourly Output Based On DIN18873-2:

Model		M12
Advised daily output		100 cups
Hourly output	Espresso (Medium 50ml)	85 cups
	Americano (Medium 240ml)	75 cups
	Cappuccino (Medium 200ml)	65 cups
Hourly hot water output		30L
Water tank capacity		Small 2L/Large 8L
Beans hopper capacity		1000g
Grounds container capacity		70pcs (10g/pc)
Drip Tray		About 1.5L

5.1.2 Technical sheet

Model	M12	M12 Big	M12 Plus	M12 Big Plus
Rated Voltage	220v-240v AC~50/60Hz			
Rated Power	2900W			
Plumbing Type	G3/4' to G3/8' 150cm flexible metal tube			
Water Pressure Range	No pressure		Max. 0.6Mpa	
Coffee machine Dimension w*d*h	With small water tank 300*500*580mm/ With large water tank 410*500*580mm			
Weight	With small water tank 19Kg/ With large water tank 20.5Kg			

6 Screenshot Description

: This is function switch icon, Orange means" Turn on", Grey means" Turn off"

6.1 Drinks Home Screen



Screenshot description

1. Touch any picture to get coffee; (see details in user manual)
2. Slide on the touch panel for page turning; (see details in user manual)
3. Data & time on top right corner, setting available in the Menu.

6.2 Language Setting



Language Setting

Enter the setting interface by tapping National Flag icon on the top left corner, and then choose the language by tapping the corresponding national flag.

Dual Language:

Tap "" to turn on bilingual display; (orange-on; Grey-off)

Turned on: The name of beverage at the first line is in language set in the menu, the second line is in English.

Turned off: The name of beverage is in language set in the menu only.

6.3 Menu



Tap  to see the Menu;

6.3.1 Brewer Rinse



Tap "Brewer Rinse" to see the interface above "Back or OK" for your choice, machine will proceed to rinse process if no response in 5 seconds.

Tap "Brewer Rinse" and hold for 3 seconds entering "Brewer Deep Clean" (see details in user manual)

6.3.2 Milk rinse





Tap "Milk Rinse" to see the interface above "Back or OK" for your choice, machine will proceed to rinse process if no response in 5 seconds.

Tap "Milk Rinse" and hold for 3 seconds entering "Milk Deep Rinse" (see details in user manual)

6.3.3 One-Button Maintenance





Tap “One-Button Maintenance.” to see the interface above “Back or OK” for your choice, machine will proceed the process if no response in 5 seconds.

6.3.4 Service Menu

Tap “Service Menu”, machine will prompt inputting password. (See details in next chapter)

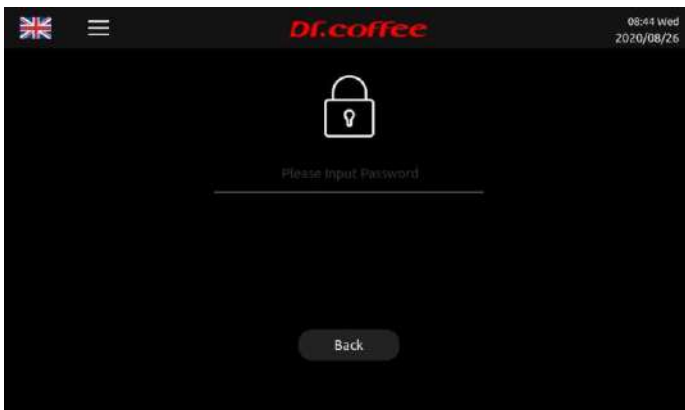

6.3.5 Wipe Protect

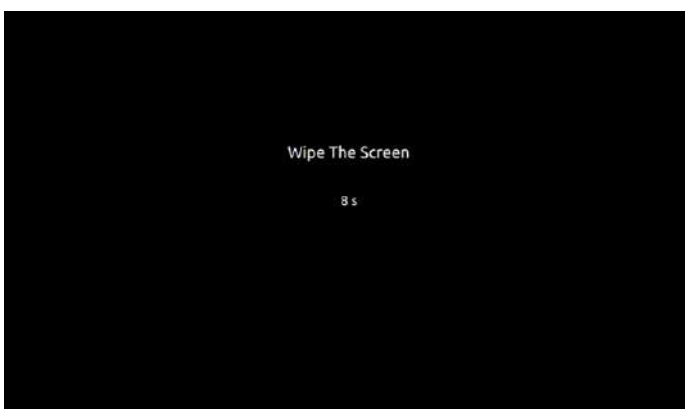

Tap “Wipe Protect”, there will be only words “Wipe Protect” with 10 seconds counting down for display wiping.

Tap “Wipe Protect” and hold for 3 seconds to enter “Descaling” process. (See details in user manual)

6.3.6 Information

Total Cups



Data Source: Tap the “Arrow” to choose the amount of “Product Cup” or “Test Cup”

Date Selection: Select the date period of data;

Time Selection: Select the time period of date

Total Cup: The quantity of cups under the condition selected (The amount of each kind of beverage is available)

Maintenance records



Maint. Records: The times amount of maintenance;

Soft. Version



Mainboard Version: Current Software Version Info of Mainboard;

HMI Version: Current Software Version Info of Mainboard;

Machine S/N: Series Number of the machine

Beverage DB Version: Current Beverage DB Version

Machine Param.DB Version: Current Machine Param.DB Version

System Version: Current Machine System Version

Machine Info.



Machine Info: Scan the QR picture to see the info below;

1. **Model:** Model of the machine;
2. **HMI Version:** Current Software Version Info of HMI;
3. **Control Version:** Current Software Version Info of Mainboard;
4. **IMEI:** The IMEI info of 4G Model; (This function is only available for IOT models.)
5. **SIM No:** The info of SIM card; (This function is only available for IOT models.)
6. **IOT No:** The number of IOT in the machine; (This function is only available for IOT models.)
7. **Enterprise No:** The number of Enterprise this machine belongs to; (This function is only available for IOT models)
8. **Net State:** The info of Net State (This function is only available for IOT models.)

6.3.7 Power Off



Tap "Power Off" to see the interface above "Back or Power off" for your choice, machine will proceed the process if no response in 10 seconds. Start rinsing process before power off

Tap "Confirm", start rinsing automatically, screen turned off and power off (press more than 5 seconds to wake up machine)

Tap "Return", return to top level automatically.

7 Service Menu

Method of Entry

Step 1: Tap “Service Menu” for entry (as picture below)

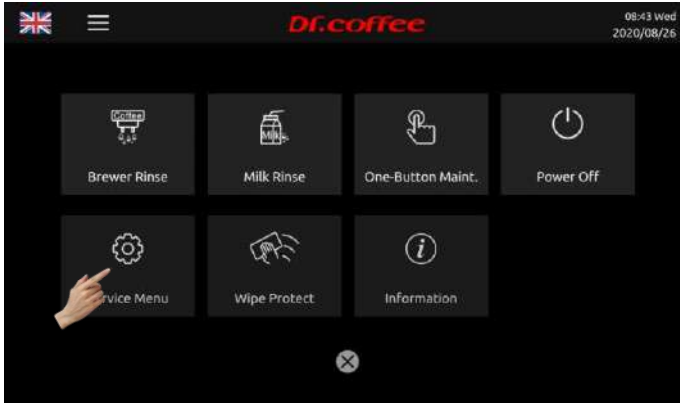

Step 2: Input correct password;

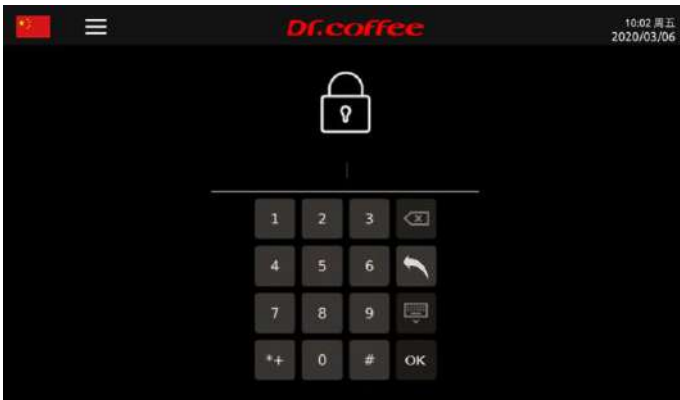

Password Level:

Primary Password: The highest level, all access to Service Menu (Including Drinks Setting, Maintenance, Machines Setting, Eng. Setting; default password is 1809)

Secondary Password: Secondary level, limited access to Service Menu (Including Drinks Setting, Maintenance, Machines Setting, default password is 1709)

Tertiary Password: Tertiary level, limited access to Service (Drinks Setting only default password is 1609)

Step 3: Service Menu Interface;



7.1 Drinks Setting

Drinks Setting: Tap the picture of beverage to modify the parameters.



7.1.1 Drinks Position Changing

Tap  then tap the aim position. Click the image of the drink that needs to be exchanged to accomplish the position exchange of the two drinks.



7.1.2 Delete Drinks

Tap  to the interface to see the interface below.

- ❖ *Cancel: Cancel this process*
- ❖ *OK: Delete this beverage.*



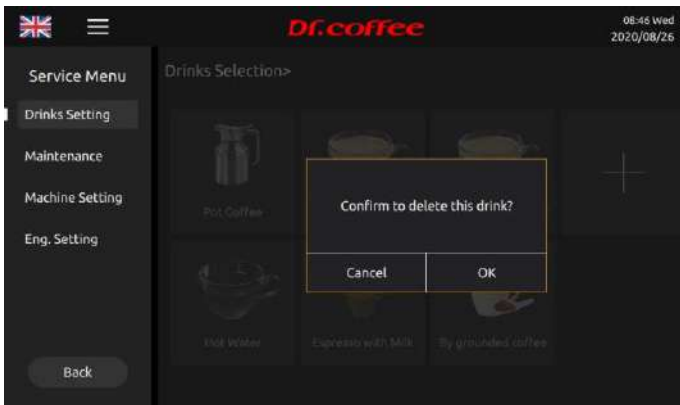

7.1.3 Drinks Parameters setting

Tap  to see the parameters setting interface.



7.1.3.1 Drink Name

This is the name of the drink.

7.1.3.2 Change to

Please fill the blank with new drink name.

7.1.3.3 Picture Changing

Step 1: Tap "the picture showing" to see all drink pictures available

(If U-disk connected, all pictures available will appear.)

Step 2: Tap the aim picture to replace.

Tap "SAVE". Picture changing accomplished.

◆ Requirements for U-Disk:

- Memory Capacity: No more than 32GB;
- Port: USB 1.0 or USB 2.0;
- Format : FAT or FAT32;
- Pictures should be under Root Directory of U-Disk

※ **Requirements of Beverage Pictures:** (The name could be English Words or numbers ONLY.)

Image Size: 332x332 pixels ;

Format :png ;

File Size: Less than 1MB;

7.1.3.4 Payment

Tap  to switch on or off payment function. The price of beverage will be shown under the beverage name.

(This function is only available for IOT models.)

7.1.3.5 Lock

Tap  to turn on or turn off this function. Locked beverage will be at the last page in drinks setting interface and there will be a lock on it.

If locked beverage will not be shown in the Drinks Menu.

7.1.3.6 Small Cup

Tap  to turn on or turn off this function.

7.1.3.7 Medium Cup

Tap  to turn on or turn off this function.

7.1.3.8 Large Cup

Tap  to turn on or turn off this function.

7.1.3.9 Cup Type Selection

Set parameters for the three cup types.

7.1.3.10 Grounds

Grinding gram level, setting level:1~5,details as below::

❖ The weight of this data is calculated according to the "factory default setting". The data is the experimental value for reference only. If the difference is subject to actual conditions.(Tolerance: ±1g):

Comparison Table

Grounds	1	2	3	4	5
Gram	7g-8g	9g-10g	11g-12g	13g-14g	15g-16g



7.1.3.11 Pre-brewing(s)

The coffee powder pre-soaking time, unit: S, setting level: 0~5

7.1.3.12 Coffee (ml)

The amount of coffee flowing out, unit: ml. Setting level: See the screen numerical on the interface, different beverage with different beverage value limits.

7.1.3.13 Cold water(ml)

The amount of warm water flowing out, unit: ml. setting level: See the screen numerical on the interface, different beverage with different beverage value limits.

7.1.3.14 Circle-index

Brewer working times of beverage making. Choices: 1~5

7.1.3.15 Brew Pressure

The pressure of coffee making Choice: Yes, No ("Yes" means making coffee with presser; No means making coffee without pressure)

7.1.3.16 Hot water (ml)

The amount of Hot water Unit: ml Setting range: Please refer to the screen value input interface. Different drinks have different tolerance.

7.1.3.17 Milk (s)

The time of milk output Unit: s Setting range: Please refer to the screen value input interface. Different drinks have different tolerance.

7.1.3.18 Milk Foam (s)

The time of milk foam output Unit: s Setting range: Please refer to the screen value input interface. Different drinks have different tolerance.

7.1.3.19 Waiting (s)

The time between step to step Unit: S. Setting range: Refer to the prompt on the screen value input interface.

7.1.3.20 Extraction Control

Set the extraction control for making drinks. Setting Range: standard; strong; extra strong

7.1.3.21 Temperature Range

The temperature for making drinks adjustable:High;Medium;Low

7.1.3.22 Order

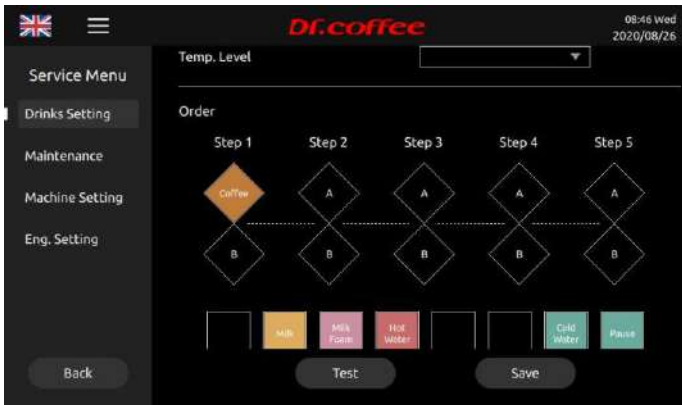

The order of material output during coffee making.

Different icons represent different materials.

Step 1~ Step5 means the coming out order. According to demands slide the icons to blanks of different steps.

(If two blanks in the same step are filled the materials will come out at the same time.)

Test

Beverage test making with the parameters set.

Save

Save the parameters.

Back

Back to the previous menu.

7.1.4 Create new beverage

Tap  to create a new beverage;



First step:

Follow the instructions on the screen, set the parameters in the required options, define the order of beverages, and then save:



Second step:

Re-enter the "Drinks Setting" menu, unlock the newly created drink, set the drink picture, and save the detailed content inside.



❖ **Remarks:** Save the parameters of "small cup", "medium cup" and "large cup" in the "cup type selection" option. (Otherwise, it may happen that the beverage cannot be prepared normally due to incomplete beverage parameters.)

7.2 Maintenance



7.2.1 Brewer Deep Clean



Use professional cleaning tables to do deep clean. Follow the instruction to finish this process.

❖ See details in User Manual.

7.2.2 Milk Deep Clean



Use professional cleaning tables to do deep clean. Follow the instruction to finish this process.

❖ See details in User Manual.

7.2.3 Descaling



Use professional cleaning powder to do descaling. Follow the instruction to finish this process.

❖ See details in User Manual.

7.2.4 Water Draining



Empty the remaining water in the internal piping of the coffee machine to prevent it from freezing and causing cracking after transporting in a low temperature environment.

Follow the instruction to finish this process.

❖ See details in User Manual

7.2.5 Filter

Filter: Set the Filter(Only in tank water supply mode, the filter element function can be activated and the filter element can only be installed in the 8 liter tank)



Install the Filter: Indicates the operation to install the filter element. After clicking "Install the filter element, the screen will prompt you to install the filter element.



Replace the Filter: Indicates the operation of replacing the filter element. After clicking "Replace the filter element, the screen will prompt the operation steps to replace the filter element.

Cancel the Filter: Indicates to cancel the filter function

Filter replacement cycle comparison table:

Water hardness setting	0-75ppm	76-150ppm	151-300ppm	>300ppm
Filter replacement cycle	400L	300L	200L	100L

For Example: if water hardness is: 0-75ppm: Indicates that after the water consumption reaches 400L, the machine will prompt to replace the filter element;

7.3 Machine Setting

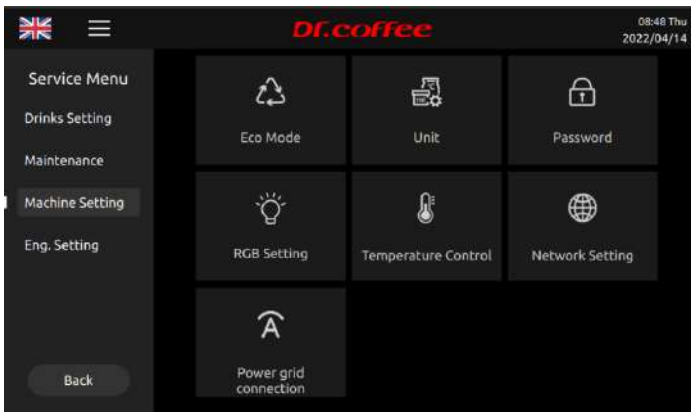
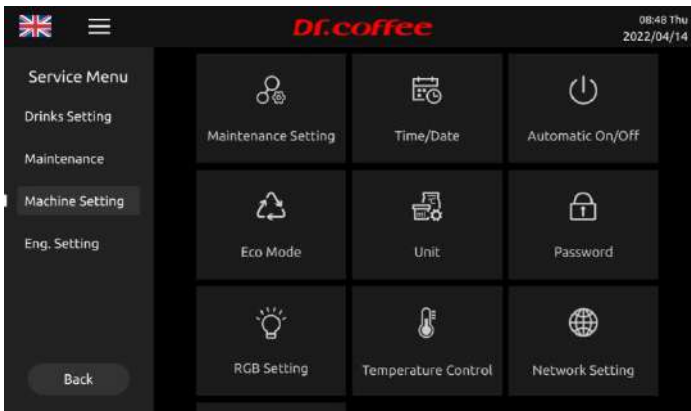

7.3.1 Maintenance Setting

Maintenance Setting: Set the condition values for various maintenance intervals of the machine. Tap "Save" to effect.

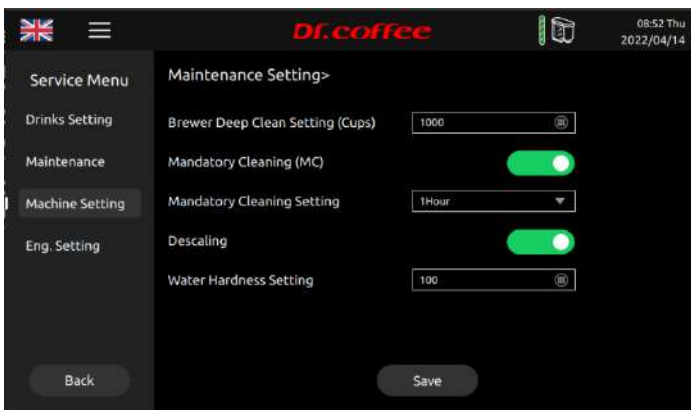

Brewer Warming Up

This indicates brewer warming up function actives by hot water flowing through the whole brewing system.

- ❖ For example: Setting "20 minutes later" which means that if the coffee machine is not operated after 20 minutes, the machine will turn on the warm-up function.
- ❖ Specific explanation of this function: make any coffee drink after 20 minutes, will pop up the prompt "Brewer warming up?", click "yes", the coffee machine will automatically flush the brewing system with hot water to achieve the effect of preheating.

Brewer Deep Clean Setting (Cups)

This indicates how many cups of coffee to make; the machine will automatically prompt you to use the tablets for deep cleaning of the brewing system.

The unit is: cup. Setting Choice: 1000~5000cups

Milk Rapid Rinse Setting

This indicates the function will active after setting. Setting Choice: No, Immediate, 5 min Later, 10min Later, 15min Later, 20min Later, 2H Later

- ❖ If “No”, the function will not active.
- ❖ If “Immediate”, the function will active after each cup of milk coffee made.
- ❖ If “5min Later”, the function will active 5 minutes after each cup of milk coffee made.

Milk Deep Cleaning Setting (Cups)

This indicates how many cups of milk coffee made; the machine will prompt this function need to active with milk detergent. Setting Choice: 50~1000

- ❖ For Example: Setting “500”, It will prompt “milk deep cleaning setting” after making 500 cups of beverages. Need to rinse with descaling powder.

Water Hardness Setting (Cups)

This indicates the PPM of Water. Setting Choice: 0~999

7.3.2 Time/Date

Time/Date: Set the date and time of the coffee machine system. Tap “Save” to effect.



Time Zone

This indicates the time zone setting of machine.

Time

This indicates the time for setting the coffee machine system. Setting Choice: hours, minutes

Date

This indicates the date the coffee machine system is set. Setting Choice: year, month, date.

12/24H

This indicates the system for setting the time of the coffee machine system. Setting Choice: 12-hour, 24-hour

7.3.3 Unit

Unit: Different units can be selected as needed. Tap “Save” to effect.



Capacity Unit:

Choice: ml; Oz

Temperature Unit:

Choice: °C; °F.

7.3.4 Password

Password: The password of Service Menu entry.



Instructions of Password

Primary Password: The highest level, all access to Service Menu (Including Drinks Setting, Maintenance, Machines Setting, Eng. Setting; default password is 1809)

Secondary Password: Secondary level, limited access to Service Menu (Including Drinks Setting, Maintenance, Machines Setting, default password is 1709)

Tertiary Password: Tertiary level, limited access to Service (Drinks Setting only default password is 1609)

7.3.5 RGB Setting

RGB Setting: Settings of RGB lights.



Screen backlight brightness: Slide the progress bar to adjust the brightness of the screen backlight;

RGB Color: Choose the color of the light;

Cycle interval (s): The interval time for light color switching, Unit: S, Choose Range: 1~60s

7.3.6 Temperature Control Setting

Temperature control Setting: Select the temperature model. Tap “Save” to effect.



Temperature Model

Selections: Coffee Milk、Coffee American。

- ❖ Coffee Milk Model: Indicates that the temperature control of the steam thermo block has been maintained at a high temperature that can produce steam at any time when the coffee machine is in normal work or standby state;
- ❖ Coffee American Model: Indicates that the temperature control of the steam thermo block has been maintained at the same temperature as the coffee thermo block when the coffee machine is in normal operation or standby state;

7.3.7 Network Setting

Network setting: Turn on or Turn off network here.



IOT switch: Tap “”, Turn on or turn off IOT function; (This function is only available for IOT models.)

SIM: Tap “”, Turn on or turn off 4G function;(This function is only available for IOT models.)**(optional)**

Wi-Fi: Tap “”, Turn on or turn off WiFi;(This function is only available for IOT models.) **(optional)**

Network: The WiFi hotspots searched by the machine are displayed in time, and they are automatically sorted according to the strength of the signal. The success or failure of the WiFi connection will be automatically displayed in the interface;

※ **Remark 1:** This function is only available for models with WiFi mode.

※ **Remark 2:** WiFi and 4G cannot be turned on at the same time; (if 4G is turned on, WiFi will be automatically turned off; if WiFi is turned on, 4G will be turned off automatically)

7.3.8 Automatic On/ Off

Auto Power On/ Off: Set the time for the coffee machine to automatically shut down. Tap “Save” to effect



Date Selection: Choose date. choose range: Monday, Tuesday, Wednesday, Thursday, Friday, Saturday, Sunday, Every day. Choose execution time. choose range:00:00-23:59

Auto Power On: Tap “”to turn on or turn off this function. (orange-on; grey-off): after setting, please “save”

Auto Power Off: Tap “”to turn on or turn off this function. (orange-on; grey-off): after setting, please “save”

Click“+”, add automatic on/off time setting. Power-on and power-off setting can be increased by 7 respectively

7.3.9 ECO Mode

ECO Mode: In this item, you can choose to turn on or off any of the modes. Tap “Save” to effect.



ECO 1

※ After standing by for 1 hour, the temperature of Steam Thermo block will low down to be the same with Hot Water Thermo block.

ECO 2

※ After standing by after 1 hour, the temperature of Steam Thermo block and Hot water Thermo block will low down to be 60 °C and keep status.

7.3.10 Power Grid Connection

Power Grind Connection: Click the drop-down option to select 16A or 10A mode, click Save to take effect



16A mode: Two Thermo-blocks can work at the same time (when making drinks: coffee and milk come out at the same time)

10A mode: Two Thermo-blocks cannot work at the same time (when making drinks: coffee and milk cannot come out at the same time)

7.4 Eng. Setting

Eng. Setting: Tap "Eng. Setting" to enter the interface.

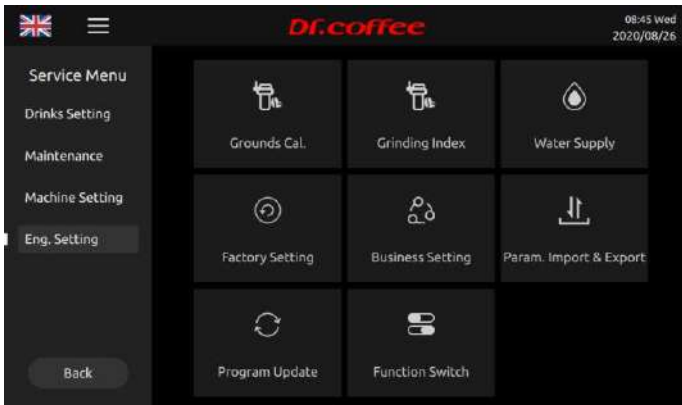

7.4.1 Grinding Calibration

Grinding Calibration: The grinding amount of the grinder can be calibrated. Tap "Save" to effect

Calibration: When the coffee machine is shipped from the factory, it is calibrated with the test beans. However, when using your coffee beans, the speed of the grinder may vary, and the amount of powder may deviate from the factory calibration standard. Therefore, it is recommended to do ground cal. with your own coffee beans before using the coffee machine.



Steps:

Step 1: Empty grounds container, place it on the balance scale, weigh it, and then put it back in the machine;

Step 2: Tap "Run" to start grinding coffee grounds will fall into the grounds container;

Step 3: Take out the grounds container and weigh the coffee powder; (Note, Weighing from the 3rd time, the first 2 times is to make sure there are coffee grounds in the grinder.)

Step 4: Enter the weight of the coffee powder into the "Grounds" on the machine interface; (Enter the value as an integer, round to the nearest decimal point);

Step 5: After repeating the steps above 3 times, "Save" will appear, and all the steps of calibration will be completed after tapping.

Then repeat the steps above for calibration of another grinder.

7.4.2 Grinding Index

Grinding Index: The grinding amount of the grinder can be calibrated. Tap "Save" to effect.

About Grounds Calibration: It is the multiple of the Grounds set in drink setting. Set Choice: 0.7~1.3; Default: 1.0

Grounds	1	2	3	4	5
Gram	7g~8g	9g~10g	11g~12g	13g~14g	15g~16g



※ For example: Choose "0.9", then all the grounds will be 90% of the original weight according to the grounds table above

Grounds	1	2	3	4	5
Gram (±1g)	(7g~8g) x0.9	(9g~10g) x0.9	(11g~12g) x0.9	(13g~14g) x0.9	(15g~16g) x0.9

7.4.3 Water Supply

Water Supply: set the way of water from.



Water Supply

Select the water supply method for the coffee machine. Selection range: water tank; tap water/barrel water (Note: The water supply mode set must be consistent with the actual water supply status.)

- ※ The way of water supply Setting Choice: Water Tank, Tap Water
- ※ (Note: The actual supply way should be the same with the setting in the machine.)

7.4.4 Factory Setting

Factory Setting: Restore the relevant parameters of the coffee machine to the factory default values. Click Save to take effect after restarting the coffee machine.



Drinks Reset

Tap “” and “Save” to Reset the Drinks Setting.

Eng. Setting Reset

Tap “” and “Save” to Reset the Eng. Setting.

Factory Reset

Tap “” and “Save” to Reset the whole Setting.

7.4.5 Business Setting

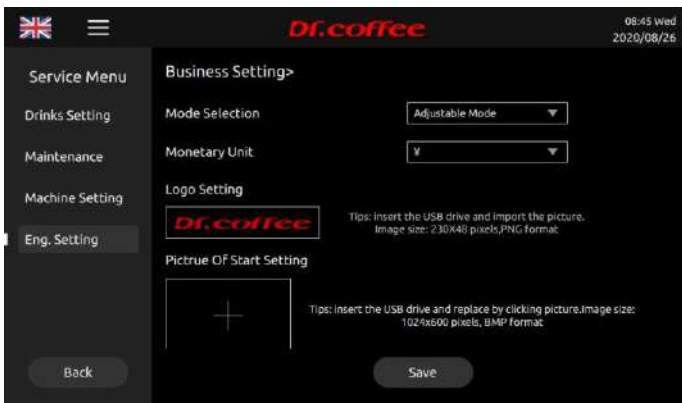

7.4.5.1 Payment Settings

Payment Settings: Turn the payment function on or off and click “Save” to effect.

7.4.5.2 Mode Selection

Click the drop-down option to select the mode. Choice: Unadjustable Mode、Adjustable Mode。

Unadjustable Mode: During making beverage, the process cannot be cancelled and the amount of the current drink cannot be adjusted.

Adjustable Mode: During making beverage, you can click Cancel at any time to adjust the amount of the current drink; *(In the mode, click “+”, Pop-up adjustment interface)*

7.4.5.3 Monetary Unit

Click the drop-down option to select the desired currency unit

7.4.5.4 LOGO setting

Step 1: Connect to U-disk, Tap "Logo showing" to see all logos available

Step 2: Tap the aim logo picture to replace.

Tap "Save". Logo changing accomplished.

◆ Requirements for U-Disk:

- Memory Capacity: No more than 32GB
- Port: USB 1.0 or USB 2.0;(USB 3.0 is not available temporarily)
- Format : FAT or FAT32;

※ LOGO Pitcture Requirements:

(File name of picture: Only English words or number)

Image Size:230x48 pixels;

Format: png;

File Size: Less than 100KB;

7.4.5.5 Picture of Start Setting

Step 1: Connect to U-disk, Tap "start showing" to see all pics available

Step 2: Tap the aim picture to replace.

Tap "Save". Start Pic. changing accomplished.

◆ Requirements for U-Disk:

- Memory Capacity: No more than 32GB
- Port: USB 1.0 or USB 2.0;(USB 3.0 is not available temporarily)
- Format : FAT or FAT32;

※ Start picture Requirements:

(File name of picture: Only English words or number)

1. Image Size: 1024x600 pixels;

2. Format: **BMP**;

3. File Size: Less than 2MB;



7.4.5.6 Screen Setting

Step 1: Connect to U-disk, Tap "Screen Setting" to see all logos available

Step 2: Tap the picture to replace,

Tap "Save". Screen Setting changing accomplished.

◆ Screen Pitcture Requirements:

(File name of picture: Only English words or number)

Image Size:1024x600 pixels; Format: png; File Size: Less than 1MB;

7.4.5.7 Enter Screen Saver Setting (min)

Unit: Minute Range: 1~10min;

For Example: If set "5 min." means the Screen Saver will show up.

7.4.5.8 Exit screen saver setting (min)

Unit: Minute Range: 1~10min:

For Example: If Set "5" minutes, means that the machine will automatically exit the screensaver mode after 5 minutes of unattended use in the screen saver state

7.4.5.9 Screensaver interval time(s)

Interval time for playing each screensaver picture Unit: Minute Range: 1~60S:

For Example: If set "15s" means the picture will change every 15s.

7.4.5.10 Advertising Mode

Pictures: Pictures loop while beverage making.



Advertising mode; change range: pic.; vedio .

❖ Requirements for U-Disk:

- *Memory Capacity: No more than 32GB*
- *Port: USB 1.0 or USB 2.0;(USB 3.0 is not available temporarily)*
- *Format : FAT or FAT32;*

❖ Advertising Pitcture Requirements:

(File name of picture: Only English wrods or number)

Image Size: 764x500 pixels; Format: png; File Size: Less than 2MB;

7.4.6 Parameters Import & Export

U-Disk for machine setting should follow the requirements below:

- ◆ **Requirements for U-Disk:**
 - *Memory Capacity: No more than 32GB*
 - *Port: USB 1.0 or USB 2.0;(USB 3.0 is not available temporarily)*
 - *Format : FAT or FAT32;*



7.4.6.1 Drinks Param.

Connect to U-Disk and follow the tips in the interface to import or export the parameters.

Export steps: Connect to U-Disk, tap , parameters export accomplished.

Import steps: Connect to U-Disk, tap , parameters import accomplished.

7.4.6.2 Maintenance Param.

Connect to U-Disk and follow the tips in the interface to import or export the parameters.

Export steps: Connect to U-Disk, tap , parameters export accomplished.

Import steps: Connect to U-Disk, tap , parameters import accomplished.

7.4.6.3 Machine Param.

Connect to U-Disk and follow the tips in the interface to import or export the parameters.

Export steps: Connect to U-Disk, tap , parameters export accomplished.

Import steps: Connect to U-Disk, tap , parameters import accomplished.

7.4.6.4 Engineer Param.

Connect to U-Disk and follow the tips in the interface to import or export the parameters.

Export steps: Connect to U-Disk, tap , parameters export accomplished.

Import steps: Connect to U-Disk, tap , parameters import accomplished.

7.4.6.5 Daily Record

Connect to U-Disk and follow the tips in the interface to import or export the parameters.

Export steps: Connect to U-Disk, tap , parameters export accomplished.

7.4.7 Program Update



7.4.7.1 Current Version

The version information of the current machine

7.4.7.2 Remote Latest Version

The latest system version of this model in the server cloud can be displayed in real time; (This function is only available for IOT models.)

7.4.7.3 Online Update

Click online update, you can automatically update the program through the network; (This function is only available for IOT models.)

✘ *This function will be open soon.*

7.4.7.4 USB Drive Update

U-Disk update is available.

Step 1: Open U-Disk on the computer, create a folder named " update_ipk "

Step 2: Paste the update (.ipk program) to" update_ipk" Folder.

Step 3: Connect the U-Disk to machine, tap "USB Drive Update", the system will do updating itself.

Step 4: After the whole process, Update successfully will appear in the interface, disconnect U-Disk, switch off the power, and restart the machines.

Updating done.

✘ (If it has no access to Interface, the machine could also be updated.

1, Switch off the machine; 2, Connect to U-Disk; 3, Switch on the machine; 4, Tap "USB Drive Update" in the Screen)

◆ Requirements for U-Disk:

- Memory Capacity: No more than 32GB
- Port: USB 1.0 or USB 2.0;(USB 3.0 is not available temporarily)
- Format : FAT or FAT32;
- The format of update program is ".ipk". The program should be move into a folder named"update_ipk" (This is the only one useful name.)

7.4.8 Function Switch

Function Switch: This is where you can turn on or off the relevant functions in the menu. Click save to take effect



Grounds Counter

Tap  to switch on or off the function. Default: On (Orange: on Grey: off)

If "On", after setting cups of coffee made, the machine will alarm. Please empty the grounds container and tap "Empty" in the Screen after closing the door.

If "Off", the machine will not alarm any more. Please check and clean grounds container in time.

Steam Thermo Block Switch

Tap  to switch on or off the function. Default: Off (Orange: on Grey: off)

If "On", the machine will use the steam thermo block, and it will be heated normally when working, and the steam-like function can be produced;

If "Off", the machine will never use the steam thermo block, and will not heat it when it is working, and all beverage that require steam production will automatically turn grey;

Descaling Switch

Tap  to switch on or off the function. Default: On (Orange: on Grey: off)

If "On", the machine will prompt "Descaling required" when the accumulated beverages produced by the machine reach the conditions set in the "Maintenance Settings" menu.

If "Off", the machine will never prompt "Descaling required", Please check and descaling in time.

If choose "off", it'll prompt: "Note :when this function is turned off, please make sure to use pure water with TDS<100, otherwise long-term use will easily lead to blockage of the machine pipeline. "

Mandatory Cleaning

Tap  to switch on or off the function. Default: On(Orange: on Grey: off)

If "On", Machine will alarm that "Milk Deep Rinse" is needed to be done at the time set in "Time of MC Setting" **EVERY DAY**. Press "X" at the top right corner to close the window, but the alarm will appear again, after the next beverage made.

If "Off", the machine will not alarm at the time set in "Time of MC Setting".

The function and the time setting are independent of "Milk Deep Rinse Cups Setting" in Maintenance Setting.

If choose "Off", it will prompt: "The milk system failure caused by turning off this option is not covered by the warranty. It is recommended to turn on this function."

Time of Mandatory Cleaning Setting

The time to remind the milk to be cleaned regularly every day. Default: 18:30 Setting Choice: 00:00~23:59

8 Warning

8.1 Warning with Tips in the Screen

8.1.1 Water Tank Is Empty

Showing in the Screen	Cause	Solutions
	<ul style="list-style-type: none"> a) The water in the tank is already below the detection level; b) The water tank is not installed correctly and too far from the sensor; c) Water level sensor is broken; 	<ul style="list-style-type: none"> ➤ Take out the tank and add water, make sure the water is not higher than the "Max" line marked on the tank. ➤ Check and reinstall the water tank; ➤ Replace a new sensor;

8.1.2 Grounds Container Is Full Up

Showing in the Screen	Cause	Solutions
	<ul style="list-style-type: none"> a) The grounds count in the grounds container reaches 50 pieces or is already full 	<ul style="list-style-type: none"> ➤ Pull out the drip tray, take out the grounds container, and empty the container

8.1.3 Bean Hopper Empty

Showing in the Screen	Cause	Solutions
	<ul style="list-style-type: none"> a) The coffee beans in the bean box have been used up; b) Beans stick together ; 	<ul style="list-style-type: none"> ➤ Add the appropriate amount of coffee beans; ➤ Mix the beans to avoid sticking together;

8.1.4 Drip Tray Is Not In Place

Showing in the Screen	Cause	Solutions
	<ul style="list-style-type: none"> a) Not well fixed; b) The sensor doesn't work; c) The induction magnet is missing or damaged 	<ul style="list-style-type: none"> ➤ Replace and fix the drip tray ➤ Change sensor; ➤ Change induction magnet;

8.1.5 Drip Tray Is Full Up

Showing in the Screen	Cause	Solutions
	<ul style="list-style-type: none"> a) The wastewater in the drip tray has reached the detection position b) The sensor is dirty. 	<ul style="list-style-type: none"> ➤ Remove the water drip tray and empty the water, and rinse it off under running water. ➤ Dry up the detective sensor

8.1.6 Waste Water Bucket is Full *(This function is only available for customized models)*

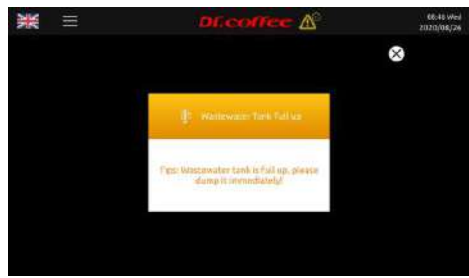
Showing in the Screen	Cause	Solutions
	<ul style="list-style-type: none"> a) Waste water bucket is full b) The sensor is dirty; 	<ul style="list-style-type: none"> ➤ Remove the waste water bucket and empty the water; ➤ Dry up the detective sensor

8.1.7 Coffee Thermo Block Over-heated

Showing in the Screen	Cause	Solutions
	<p>a) Temperature is over 160°C</p>	<ul style="list-style-type: none"> ➤ Wait, as the tips in the Screen “The coffee thermo block is cooling down, please wait ...”; ➤ While the coffee thermo block is cooling down, no beverage could be made.

8.1.8 Steam Thermo Block Over-heated

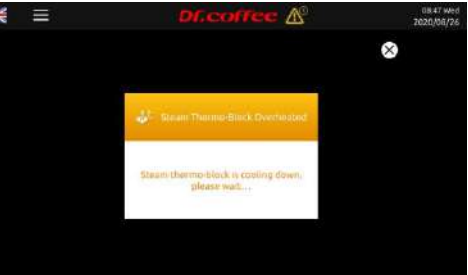
Showing in the Screen	Cause	Solutions
	<p>a) Temperature is over 160°C</p>	<ul style="list-style-type: none"> ➤ Wait, as the tips in the Screen “The Steam thermo block is cooling down, please wait ...”; ➤ While the Steam thermo block is cooling down, no beverage could be made.

8.1.9 Coffee Thermo Block Temp. Is Too Low

Showing in the Screen	Cause	Solutions
	<p>a) Temperature of it is lower than set.</p>	<ul style="list-style-type: none"> ➤ Wait, as the tips in the Scree “The coffee thermo block is heating up, please wait ...”; ➤ While the coffee thermo block is heating up, no beverage could be made.

8.1.10 Steam Thermo Block is Too Low

Showing in the Screen	Cause	Solutions
	<p>a) Temperature of it is lower than set.</p>	<ul style="list-style-type: none"> ➤ Wait, as the tips in the Screen “The steam thermo block is heating up, please wait ...”; ➤ While the steam thermo block is heating up, no beverage could be made.

8.1.11 The Hot Water Thermo Block Temp. is Too Low

Showing in the Screen	Cause	Solutions
	<p>a) Temperature of it is lower than set. (When Temp. Mode is “Coffee American”)</p>	<ul style="list-style-type: none"> ➤ Wait, as the tips in the Scree “The hot water thermo block is heating up, please wait ..”; ➤ While the hot water thermo block is heating up, no beverage could be made.

8.1.12 Environment Temp. Is Too Low

Showing in the Screen	Cause	Solutions
	<p>a) The temperature of the environment is 0℃ or lower;</p>	<ul style="list-style-type: none"> ➤ Please power on the machine when the temperature of environment is 10℃ ~ 40℃.

8.1.13 Lack of Water

Showing in the Screen	Cause	Solutions
	<ul style="list-style-type: none"> a) Tap water is lack of water; b) The connector of inlet pipe is loosed ; O-ring doesn't work or is missing; c) The inlet of tank or tap water is blocked. d) The tank is unfixed; e) The strainer of Brewer is blocked; f) The Pump damages; g) The flow meter damages; 	<ul style="list-style-type: none"> ➤ Check the way of water supply both the setting in the machine and in the reality. Tap "Fill Water"; ➤ Check if the connector or O-ring are installed correctly; ➤ Clean the inlet of tank or tap water; ➤ Re-fix the tank. Push it to the end; ➤ Clean the strainer by Brewer Deep Clean with tablets or by dissembling; ➤ Replace a new Pump; ➤ Replace a new Flow meter; ➤ Switch off and restart the machine;

8.1.14 Pressure Overloaded

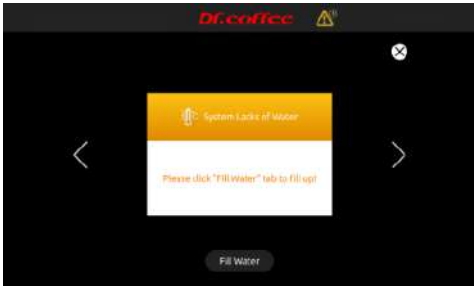
Showing in the Screen	Cause	Solutions
	<ul style="list-style-type: none"> a) The pipe or strainer of Brewer is blocked; b) Coffee Grounds from Grinder are too fine; c) The amount Coffee Grounds from Grinder are over the max capacity of Brewer; d) Air is coming into the Pump while coffee making; 	<ul style="list-style-type: none"> ➤ Tap "Rinse" to rinse Brewer; ➤ Adjust the gear position of the coffee machine to clockwise. The bigger number represents coarser. ➤ Do Grounds Calibration; ➤ If water supplied by tank, clean the Inlet of tank; If water supplied by tap water, check if there is water available, or the connector is loosed;

8.1.15 Grinder Calibration

Showing in the Screen	Cause	Solutions
	<ul style="list-style-type: none"> a) After a certain cups of coffee made, it will alarm; It will alarm at the 2000th cup, 7000th cup, 17000th cup, 27000th cup... and so on.(every 10 thousand cups) b) Turn off, will not alarm. 	<ul style="list-style-type: none"> ➤ Tap "Immediate" to do Grinder Calibration; ➤ Tap "Later" to ignore, but the yellow alarm icon will appear at the top on interface;

8.1.16 Brewer Check Up

Showing in the Screen	Cause	Solutions
	<ul style="list-style-type: none"> a) The Brewer is not in a right position; b) The Brewer damages c) The brewer transmission group is damaged 	<ul style="list-style-type: none"> ➤ Tap "Check Up"; ➤ Replace a new Brewer; ➤ Replace the brewer transmission group

8.1.17 Brewer Washing Required

Showing in the Screen	Cause	Solutions
	<ul style="list-style-type: none"> a) Reach the set value, it will alarm "brewer washing required". b) The amount of cups could be set in Maintenance Setting 	<ul style="list-style-type: none"> ➤ Follow the screen instructions, enter the service menu bar, find the corresponding function menu, and perform deep cleaning of the brewing system!

8.1.18 Milk Deep Clean

Showing in the Screen	Cause	Solutions
	<ul style="list-style-type: none"> a) Reach the set value, it will alarm "Milk Deep Clean" b) The amount of cups could be set in Maintenance Setting 	<ul style="list-style-type: none"> ➤ Follow the screen instructions, enter the service menu bar, find the corresponding function menu, and perform Milk Deep Clean.

8.1.19 Descaling Required

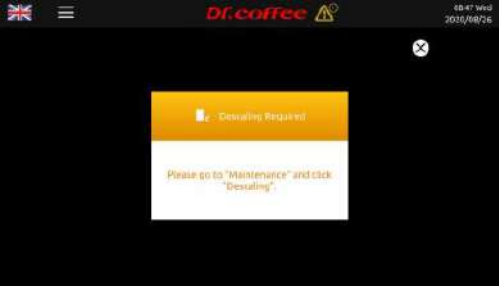
Showing in the Screen	Cause	Solutions
	<ul style="list-style-type: none"> a) After a certain cups of milk coffee made, it will alarm; b) The amount of cups could be set in Maintenance Setting 	<ul style="list-style-type: none"> ➤ Follow the screen instructions, enter the service menu bar, find the corresponding function menu, and perform Descaling.

8.1.20 No network

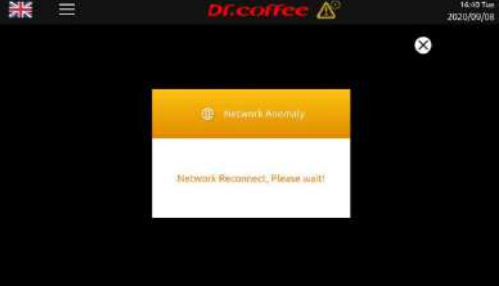
Showing in the Screen	Cause	Solutions
	<ul style="list-style-type: none"> a) 4L Signal is too weak; b) 4G SIM card Arrears or damage c) The network module in the coffee machine is damaged, causing the coffee machine to fail to connect to the Internet; 	<ul style="list-style-type: none"> ➤ Take the coffee machine to a position with good signal quality, turn off the power and restart; ➤ Renewal and use new SIM card, turn off the power and restart. ➤ Turn off the power and replace new network module, then restart the machine.

9 Trouble Shooting

9.1 Error with Tips in the Screen

9.1.1 Water Supply Error

Showing in the Screen	Cause	Solutions
	<p>a) It will appear after “Lack of water” appearing and filling water for 3 times.</p>	<ul style="list-style-type: none"> ➤ Check if the water supply is ok, switch off the machine and restart. ➤ Check if the connector of water inlet pipe or O-ring are installed correctly;; ➤ Clean the inlet of tank or tap water; ➤ Re-fix the tank. Push it to the end;; ➤ Clean the strainer by Brewer Deep Clean with tablets or by dissembling; ➤ Replace a new Pump; ➤ Replace a new Flow meter;

9.1.2 Steam Thermo Block Water Supply Error

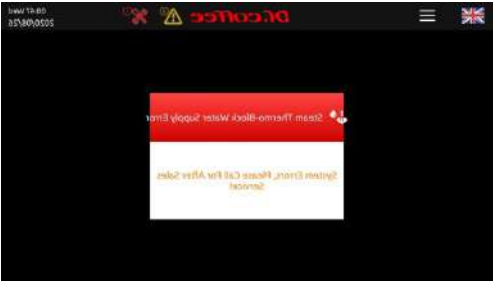
Showing in the Screen	Cause	Solutions
	<p>a) It will appear after “Lack of water” appearing and filling water for 3 times.</p>	<ul style="list-style-type: none"> ➤ Check if the water supply is ok, switch off the machine and restart. ➤ Check if the connector of water inlet pipe or O-ring are installed correctly;; ➤ Clean the inlet of tank or tap water; ➤ Re-fix the tank. Push it to the end;; ➤ Clean the strainer by Brewer Deep Clean with tablets or by dissembling; ➤ Replace a new Pump; ➤ Replace a new Flow meter;

9.1.3 Grinder Error

Showing in the Screen	Cause	Solutions
	<p>a) The Grinder is blocked or overloaded; b) The Grinder damages; c) Power PCB damages; d) Hall sensor group damages;</p>	<ul style="list-style-type: none"> ➤ Dissemble the Grinder to see if there is stone or something hard in it and remove; ➤ Replace a new Grinder; ➤ Replace a new Power PCB; ➤ Replace Hall Sensor.

9.1.4 Brewer System Error

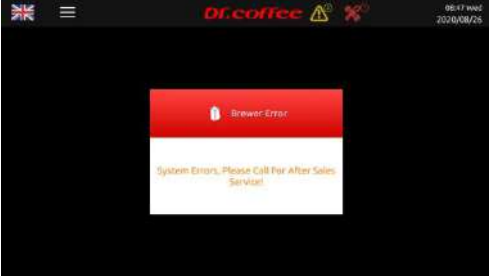
Showing in the Screen	Cause	Solutions
	<ul style="list-style-type: none"> a) The Brewer is blocked is stuck; b) The motor doesn't work; c) The Brewer damages; d) Control Board damages; 	<ul style="list-style-type: none"> ➤ Switch off the machine and restart; ➤ Disassemble the brewer to check and clean ➤ Replace a new motor; ➤ Replace a new Brewer; ➤ Replace a new Control Board;

9.1.5 HMI Communication Error

Showing in the Screen	Cause	Solutions
	<ul style="list-style-type: none"> a) Main Board and display board connection loose or damaged; b) Control software doesn't match with the HMI software; c) HMI PCB damages; d) Main Board damages 	<ul style="list-style-type: none"> ➤ Check the plugs on HMI PCB and reconnect; ➤ Update Control software and HMI Software; ➤ Replace a new HMI PCB; ➤ Replace a new Main Board.

9.1.6 Coffee Thermo Block NTC Error

Showing in the Screen	Cause	Solutions
	<ul style="list-style-type: none"> a) Connection between Sensor and mainboard damages or disconnects; b) NTC damages; c) The temperature is over 180°C; 	<ul style="list-style-type: none"> ➤ Check the connection, reconnect or replace the wire; ➤ Replace a new NTC; ➤ Switch off the machine and restart after 30 minutes for cooling down; ➤ Replace a new Coffee Thermo Block;

9.1.7 Steam Thermo Block NTC Error

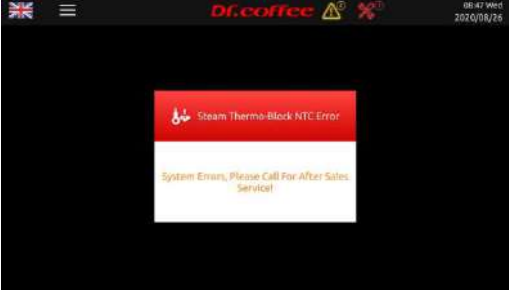
Showing in the Screen	Cause	Solutions
	<ul style="list-style-type: none"> a) Connection between Sensor and mainboard damages or disconnects; b) NTC damages; c) The temperature is over 180°C; 	<ul style="list-style-type: none"> ➤ Check the connection, reconnect or replace the wire; ➤ Replace a new NTC; ➤ Switch off the machine and restart after 30 minutes for cooling down; ➤ Replace a new Steam Thermo Block;

9.1.8 Coffee Thermo Block Heating Overtime

Showing in the Screen	Cause	Solutions
	<ul style="list-style-type: none"> a) The temperature of coffee thermo block exceeds the value of the temperature fuse, causing the temperature fuse to be blown; b) NTC sensor damages; c) Coffee thermo block damages; 	<ul style="list-style-type: none"> ➤ Turn off the machine, disassemble the cover of machine to replace fuse ➤ Replace a new NTC temperature sensor; ➤ Replace a new Coffee Thermo block;

9.1.9 Steam Thermo Block Heating Overtime

Showing in the Screen	Cause	Solutions
	<ul style="list-style-type: none"> a) The temperature of steam thermo block exceeds the value of the temperature fuse, causing the temperature fuse to be blown; b) NTC sensor damages; c) Steam thermo block damages; 	<ul style="list-style-type: none"> ➤ Turn off the machine, disassemble the cover of machine to replace fuse ➤ Replace a new NTC temperature sensor; ➤ Replace a new Steam Thermo block;

9.1.10 Hot Water Thermo Block Heating Overtime

Showing in the Screen	Cause	Solutions
	<ul style="list-style-type: none"> a) The temperature of hot water thermo block exceeds the value of the temperature fuse, causing the temperature fuse to be blown; b) NTC sensor damages; c) Hot water thermo block damages; 	<ul style="list-style-type: none"> ➤ Turn off the machine, disassemble the cover of machine to replace fuse ➤ Replace a new NTC temperature sensor; ➤ Replace a new Hot Water Thermo block;

9.2 Error without Tips in the Screen

9.2.1 Fail to Switching On

Showing in the Screen	Cause	Solutions
-	<ul style="list-style-type: none"> a) No power connection ; b) Voltage isn't high enough; c) Not Switched on d) Power PCB damages; e) The fuse of Main Power is blown; 	<ul style="list-style-type: none"> ➤ Check if the machine is connected with power; ➤ Connect the machine with acceptable power; ➤ Check if the machine is switched on; ➤ Replace a new Power PCB; ➤ Replace a new Fuse of Main Power;

9.2.2 No Milk

Showing in the Screen	Cause	Solutions
-	<ul style="list-style-type: none"> a) The milk box is empty; b) The pipe or outlet of steam is blocked; c) The pipe of steam is broken; d) The number of Air Intake is set too high. e) The Milk Frother is blocked; 	<ul style="list-style-type: none"> ➤ Refill milk to the milk box; ➤ Do Milk Deep Rinse; ➤ Disassemble the Cover of machine, check the pipe of steam. ➤ Set the number of Air Intake lower;; ➤ Disassemble and clean the Milk Frother ➤ Replace a new Milk Frother;

9.2.3 No Milk Foam, Warm Milk Only

Showing in the Screen	Cause	Solutions
-	<ul style="list-style-type: none"> a) The inlet of Air Intake Valve is blocked; b) The pipe of Air Intake Valve is blocked; c) The Air Intake Valve damages; 	<ul style="list-style-type: none"> ➤ Check the inlet and the pipe of Air Intake ➤ Replace a new Air Intake Valve.

9.2.4 No Coffee

Showing in the Screen	Cause	Solutions
-	<ul style="list-style-type: none"> a) The Coffee Grounds are too fine; b) The amount Coffee Grounds from Grinder are over the max capacity of Brewer; c) The pipe or strainer of Brewer is blocked; d) The Brewer damages; e) The Strainer of inlet valve is blocked; 	<ul style="list-style-type: none"> ➤ Adjust the gear position of the coffee machine to clockwise. The bigger number represents coarser; ➤ Do Grounds Calibration; ➤ Do Brewer Deep Rinse with tablets; ➤ Re-fix the Brewer, or replace a new Brewer; ➤ Clean Strainer or replace a new one;

9.2.5 Software System Crashed

Showing in the Screen	Cause	Solutions
-	<ul style="list-style-type: none"> a) The system stopped working and no reaction unexpectedly; 	<ul style="list-style-type: none"> ➤ Switch off the machine and restart after 5 minutes; ➤ Update the Software;

9.2.6 Leaking

Showing in the Screen	Cause	Solutions
-	<ul style="list-style-type: none"> a) Leaking at the inlet connector of machine to Tap water ; b) Leaking inside of machine; 	<ul style="list-style-type: none"> ➤ Check if the connector is loosed; ➤ Disassemble the cover of machine and find out the place leaking; ➤ Replace the parts leaking;

10 Disassembly & Assembly

10.1 Tools



Screwdriver (T10)



Screwdriver (T20)



Millimeter



Flat Screwdriver (3.2mm 口径)



Thermometer



Long nose pliers



Electronic weigher

10.2 General Disassembly

10.2.1 Disassemble Exterior Parts

10.2.1.1 Disassemble Upper Panel

Step1: Remove Beans Container Cover, and remove positioned screws with T10 .

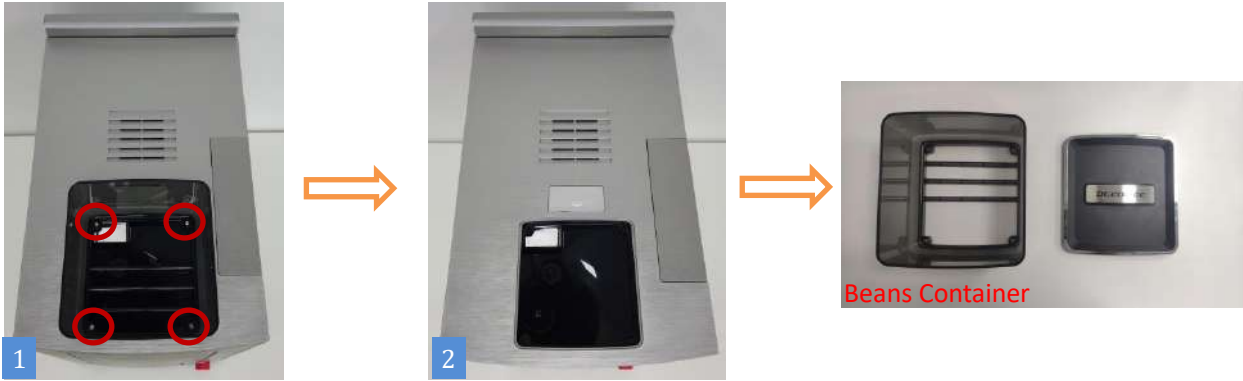

Step2: Push (Same as Pic. 3) the 8 positions, (same as pic.4) pull it up.

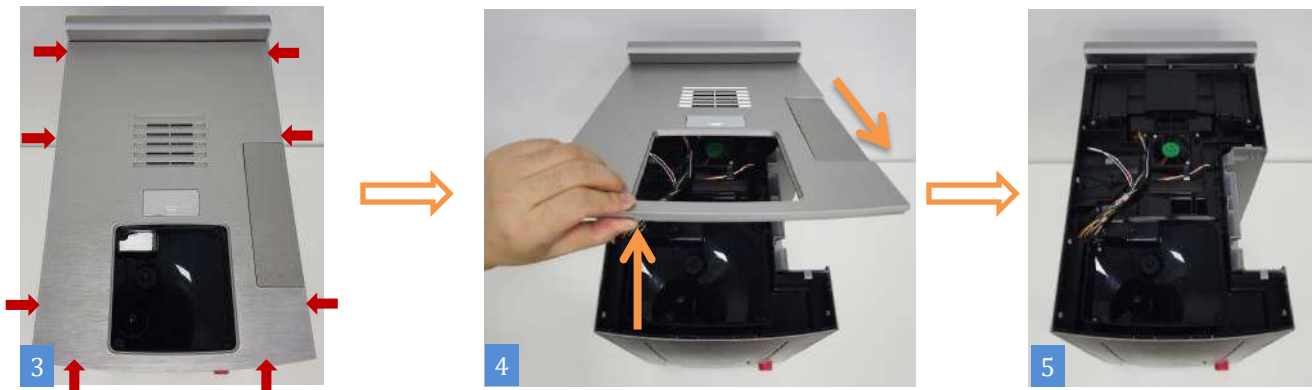

★ NOTE:

Handle with care during disassembly to prevent scratches!

10.2.1.2 Disassemble Rear Panel

Same as Pic. 1 and 2, R push the back cover from the bottom up and remove it.



10.2.1.3 Disassemble Left and Right Panel

Step 1: (same as pic.1) First gently lift the left side board to both sides and then push it up, (same as pic.2) Take out the water level detection board gently.

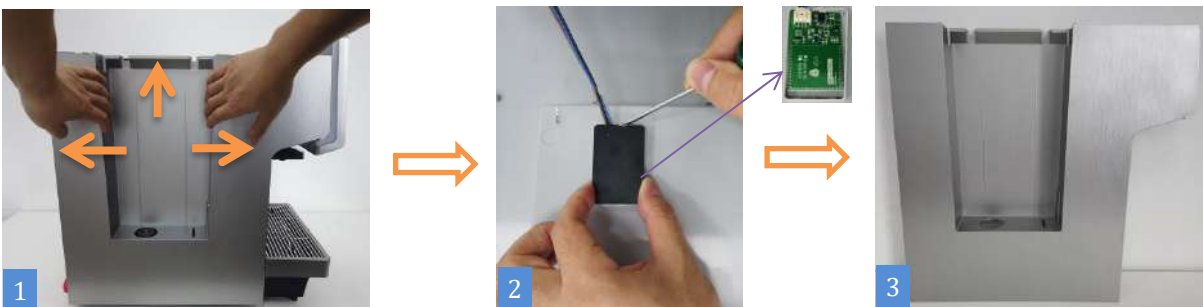

Step 2: (Same as pic.1) push the side cover from the bottom up and remove it, and remove the left side panel.

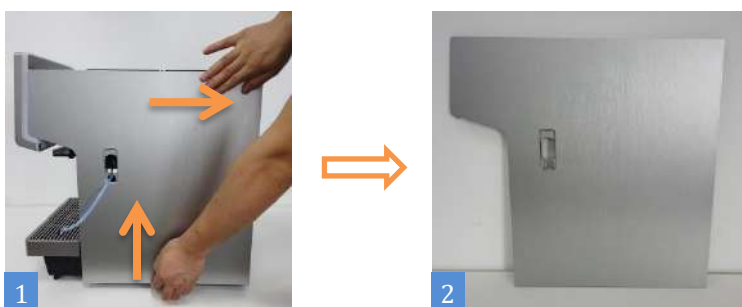

★ **NOTE:**

Handle with care during disassembly to prevent scratches!

10.2.2 Disassemble Brewer Unit

Step1: Remove screws with T10 (same as pic.1), to push the arrow position and take out the baffle ;

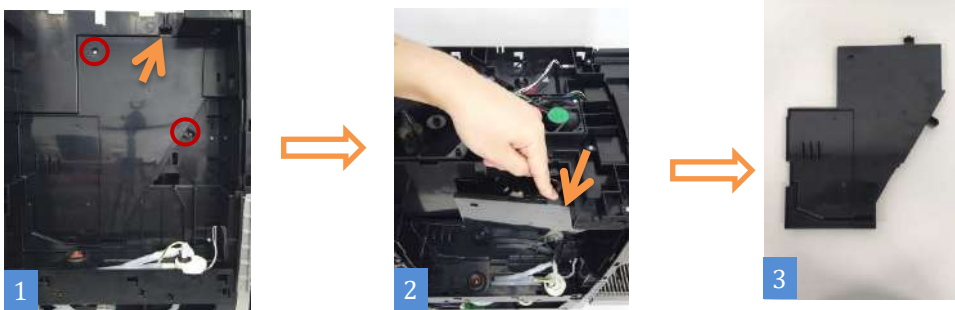

Step2: Unplug (pic.4) pipe and plug, Remove screw with T20 (pic.5), take out the brewer, over.

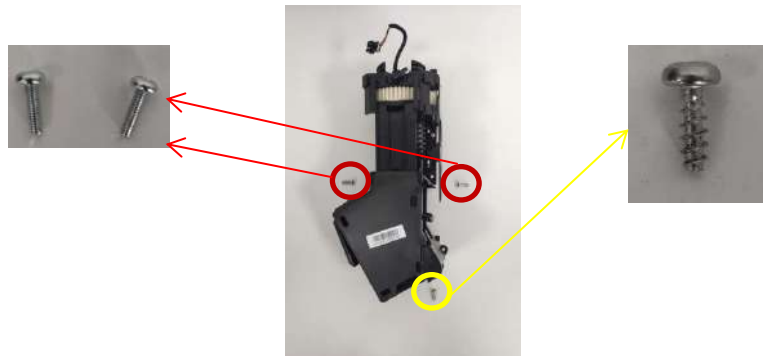
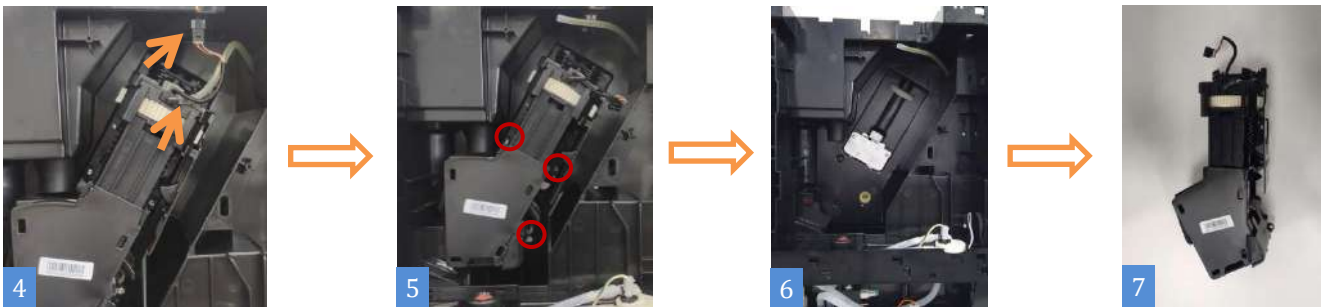

★ **NOTE:**

1. Please remove after cooling down to prevent scald!
2. Make sure the screws in correct position.

10.2.3 Disassemble Pressure Releasing Valve

Step1: First (as shown in Figure 1), hold the gear lever bracket and remove the gear lever set in the direction of the arrow.

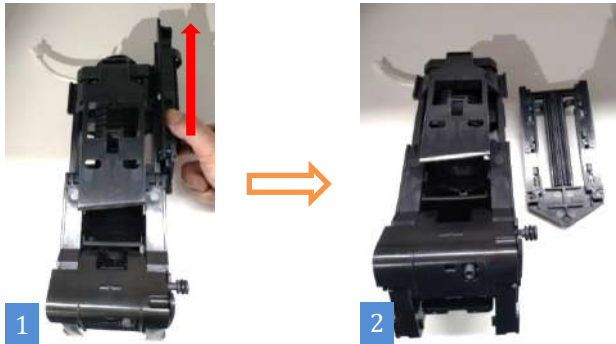

Step2: Press with a flat-blade screwdriver (as shown in Figure 1, 2), eight red circles indicate the position of the buckle, and release the buckle to remove the two side panels (Figure 3)

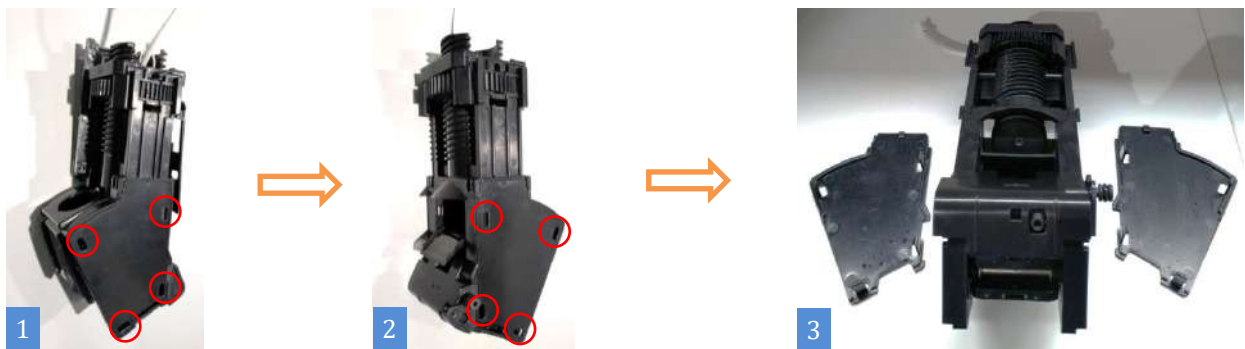

Step3: Grasp the pressure relief valve block with your hand and pull out the pressure relief valve group in the direction indicated by the arrow (Figure 1). Disassemble the group.



★ **Attention:**

- 1、Please cool down the machine before disassembling to prevent burns !

10.2.4 Disassemble Drive Motor Group

Step 1: Remove (Pic.1) plug here;

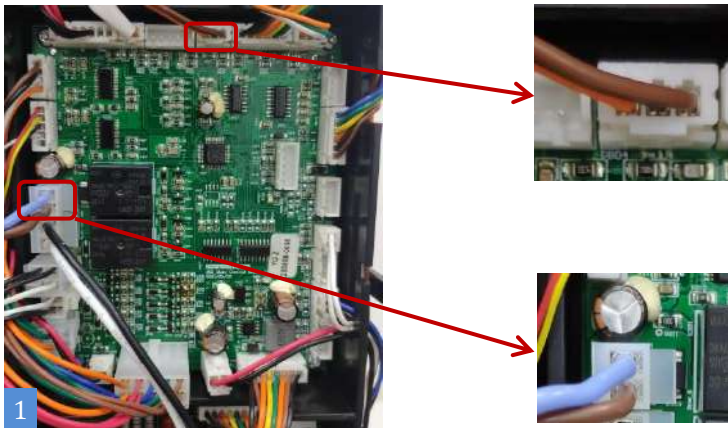

Step2: Remove the 2 screws with T20 (pic.2), grab drive motor group push down and take out.

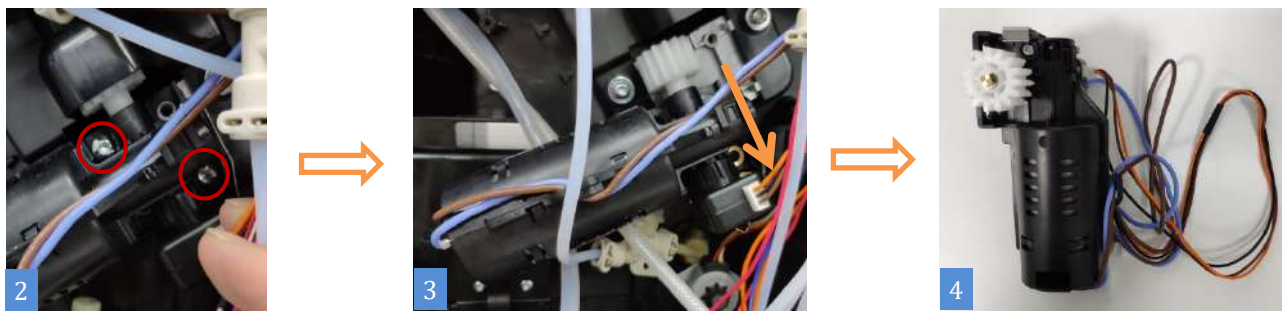

★ **Attention:**

- 1、 Please cool down the machine before disassembling to prevent burns!

10.2.5 Disassemble Pinch Valve

Step1: (Pic.1,2) Unplug all the lines here, take out the connector and unplug milk pipes.

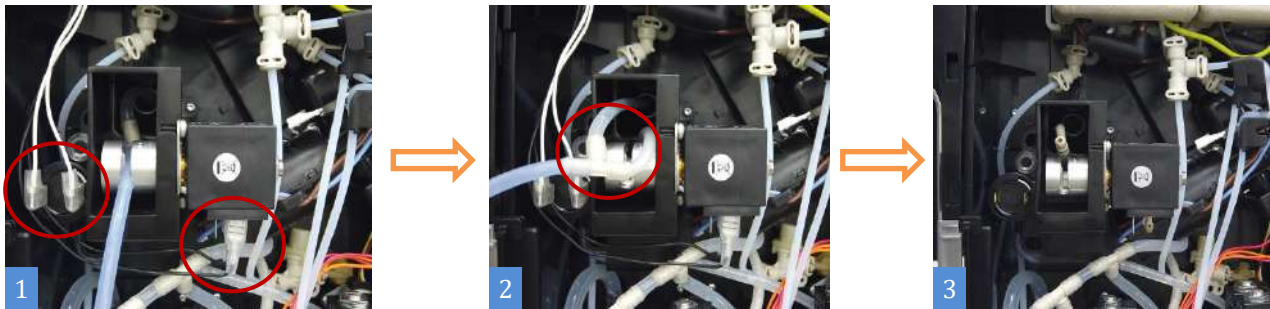

Step 2: Remove the 3 screws with T10 (Pic.4), take out pinch valve and unplug all the pipes here (pic.5) .

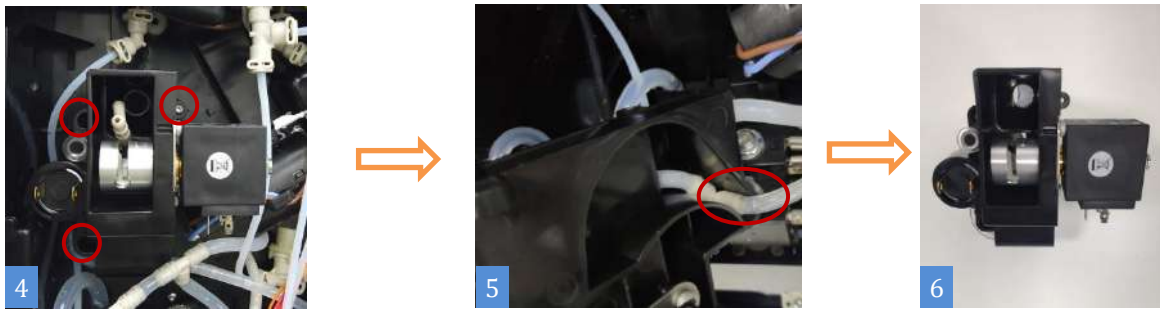

★ **Attention:**

- 1、 Be careful during the disassembly process to prevent scratching your fingers !

10.2.6 Disassemble Magnetic Valve Group

Step1: Push (pic.2) the Snap here, then remove the group from fixed card slot.

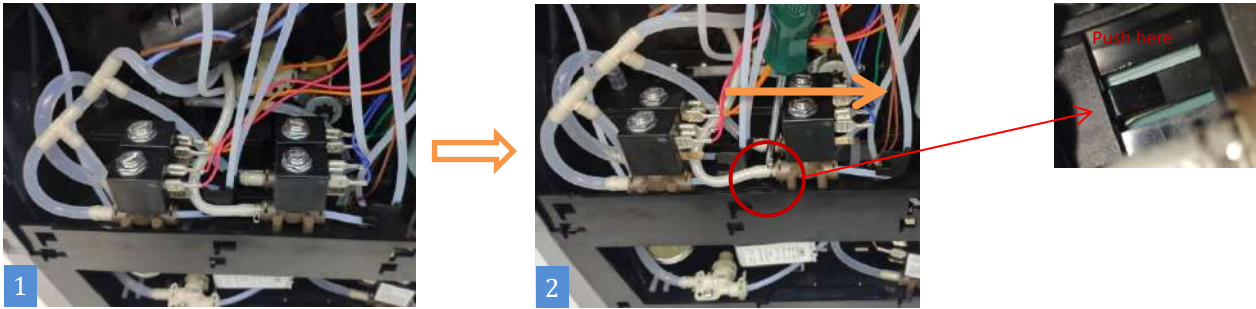

Step2: (Pic.3) Unplug all the pipes here.

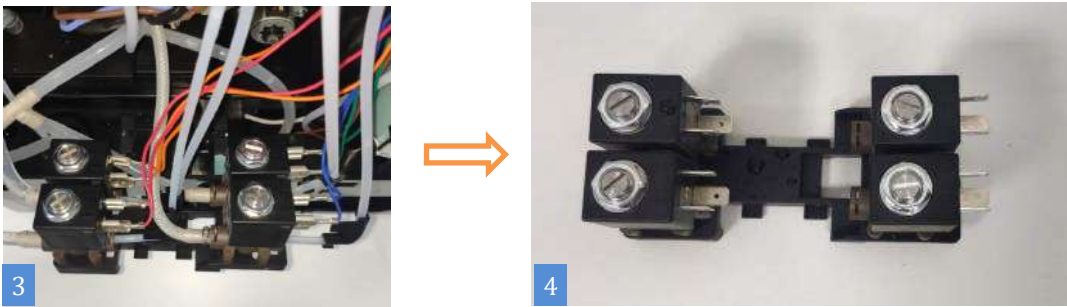

★ **Attention:**

- 2、 Be careful during the disassembly process to prevent scratching your fingers !
- 3、 Take a picture before unplug all pipes in case don't know how to put it back.

10.2.7 Disassemble Pump Group

Step1: <Water Pump> Remove the small spring clip (as shown in Figure 2) and pull out the water pipe. Then press the water pump to remove the water pump.

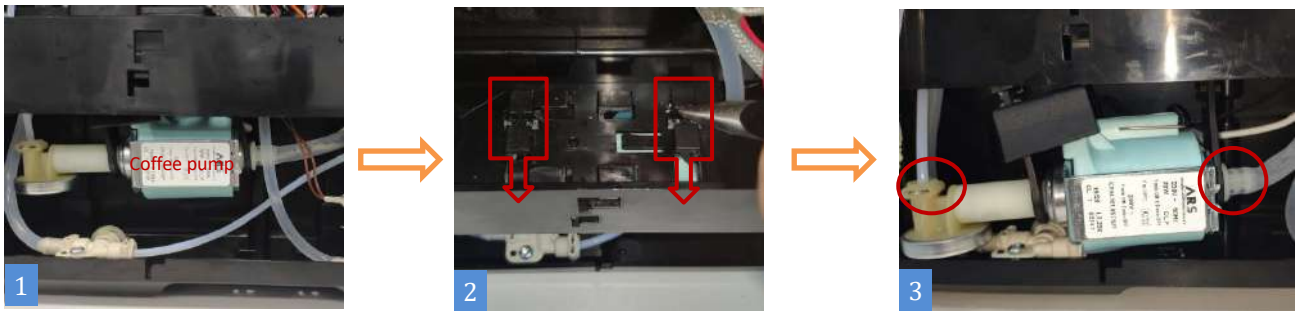

Step 2: (Pic. 4) Unplug the lines.

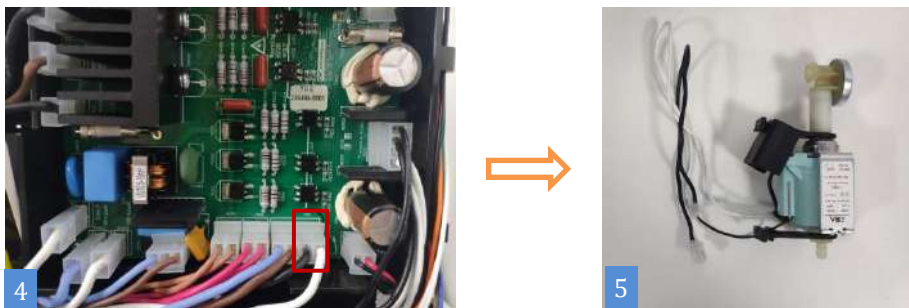

Step 1: [Steam Pump] (Pic.1) Remove the spring clip and pull out the water pipe, (pic.2) remove this way, (pic.3) take out water inlet pipe;

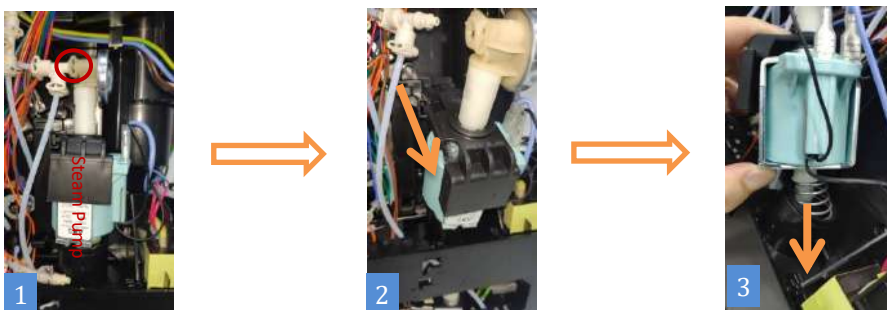

Step2: (Pic. 4) Unplug the lines.

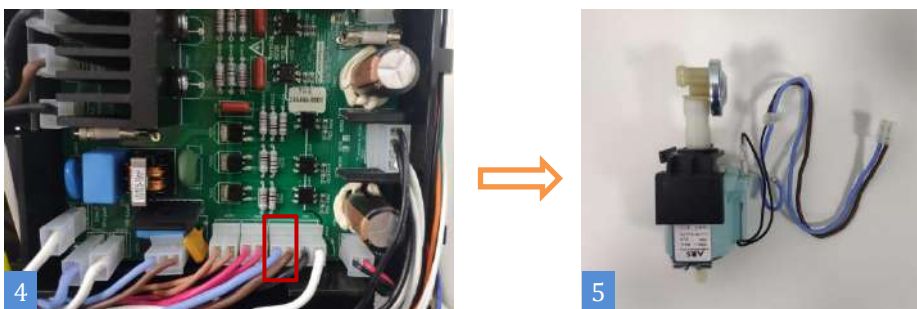

★ Attention:

- 1、 Be careful during the disassembly process to prevent scratching your fingers !

10.2.8 Disassemble Flow Meter

Step1: First unplug the wiring plug on the flow meter, then pull up the flow meter, and finally unplug the connected water pipe to take out the flow meter and disassemble the flow meter.

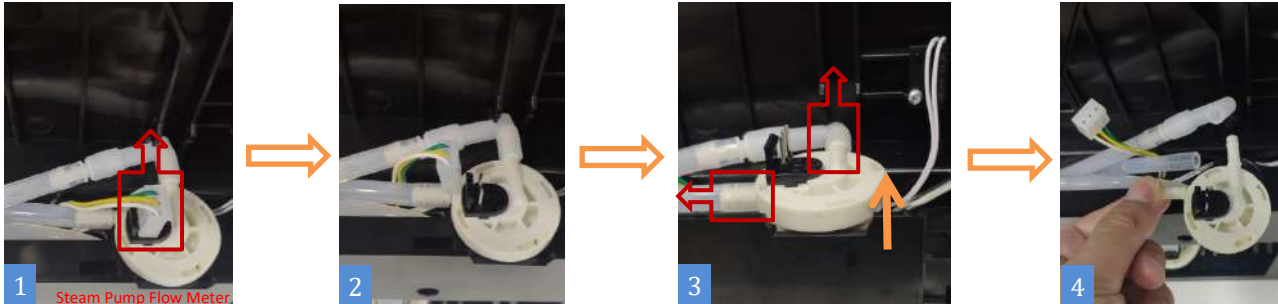

Step2: (Pic. 1) Unplug wire, then (pic. 2) pull out flow meter, (pic.3) Unplug the tube.

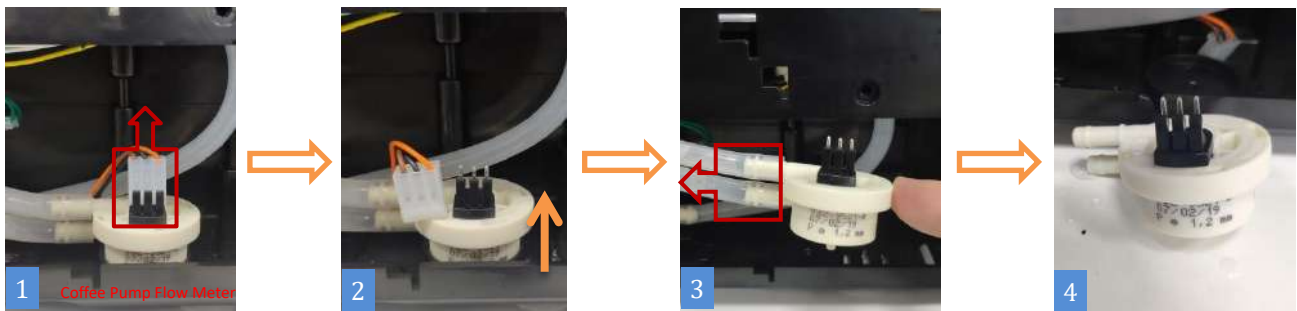

10.2.9 Disassemble Water Inlet Valve

Step: First pull out the water guide cover (can be picked up with a screwdriver), then pull up the water guide and unplug the connected water pipe.

Disassemble the water inlet valve

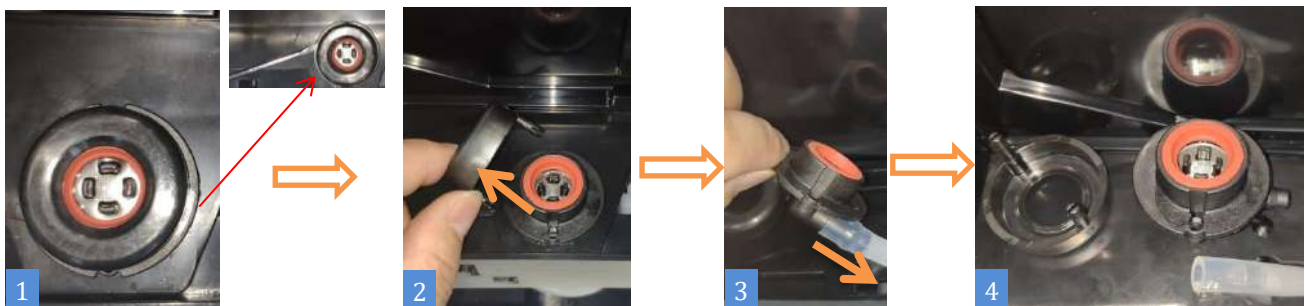

★ Attention:

- 1、 Be careful during the disassembly process to prevent scratching your fingers !
- 2、 There may be residual water in the pipe. Please prepare the water container in advance !

10.2.10 Disassemble Grinder Group

Step 1: (pic.1) First remove the bean holder;



Step 2: (pic.3) press the buckle marked with the red circle to remove the Hall sensor group, and then unplug the wiring plug on the power board (pic.4)

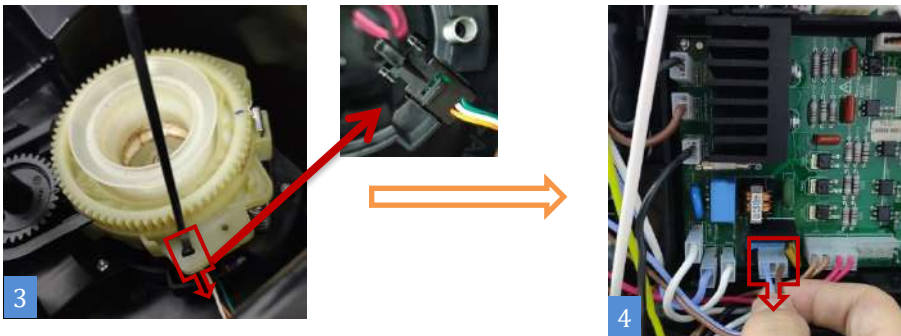

Step3: (Pic.5) Grab the parts of the grinder by hand, take out the whole grinder group upwards, and disassemble the grinder group.

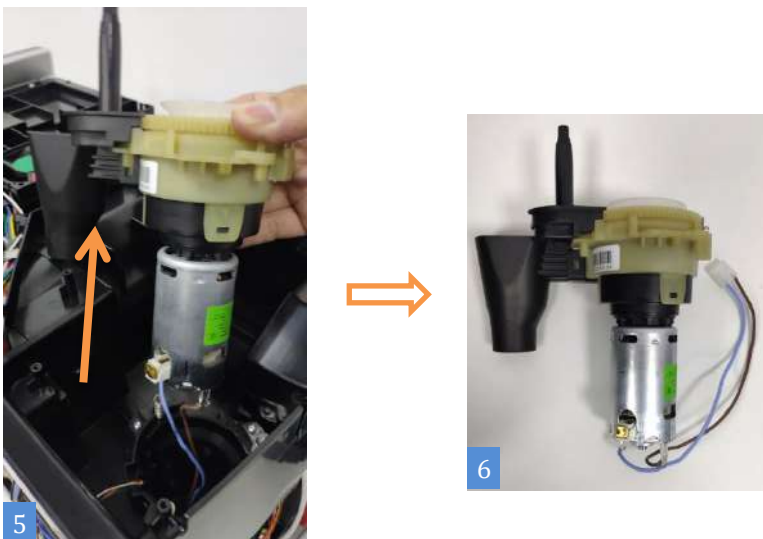

★ Attention:

- 1、 Be careful during the disassembly process to prevent scratching your fingers !
- 4、 Before removing the grinder group, please empty the residual coffee beans and coffee powder in the grinder !

10.2.11 Disassemble Thermo Block

Step1: First pull out (as shown in Figure 1, 2) the red box marked the position of the wiring plug;

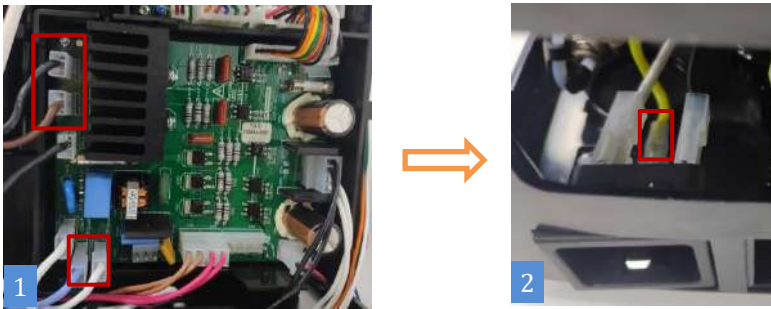

Then pull out (as shown in Figure 3, 4) the position of the wiring plug.;

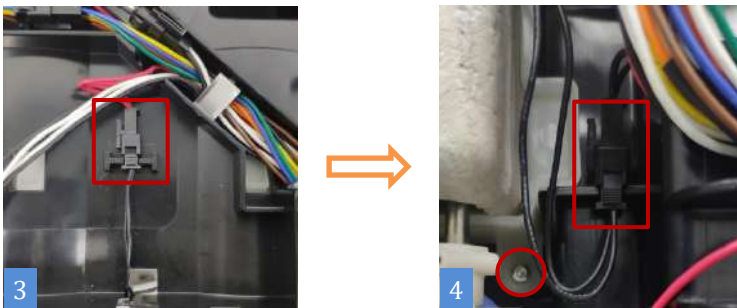

Step3: Unplug (as shown in Figure 5) the four water pipe joints indicated by the arrow, and finally unscrew the fixing screws at the position indicated by the red circle, remove the heating plate set outward, and disassemble it.

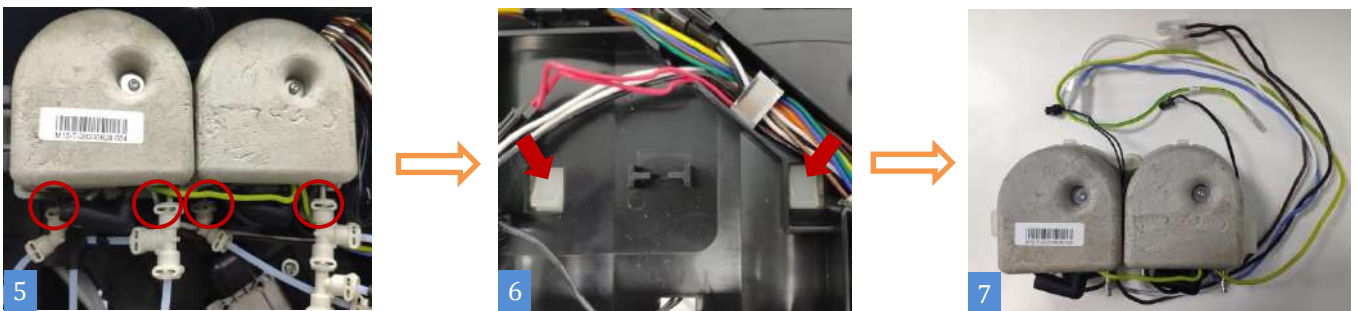

★ **Attention:**

- 1、 Unplug the coffee machine before doing this !
- 2、 Be careful during the disassembly process to prevent scratching your fingers !
- 5、 Please disassemble the coffee machine after it has cooled down completely, beware of burns. !

10.2.12 Disassemble Water Inlet Valve

Step1: Unscrew with T10.



Step2: Unplug (pic.3) the wire.

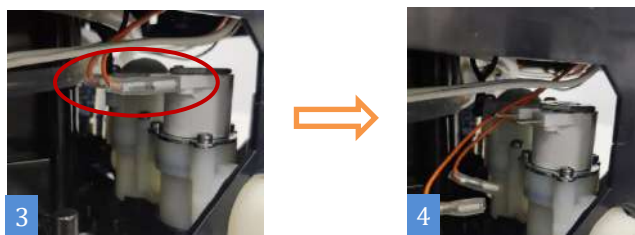

Step3: Unplug (Pic.5) plug and pipes;

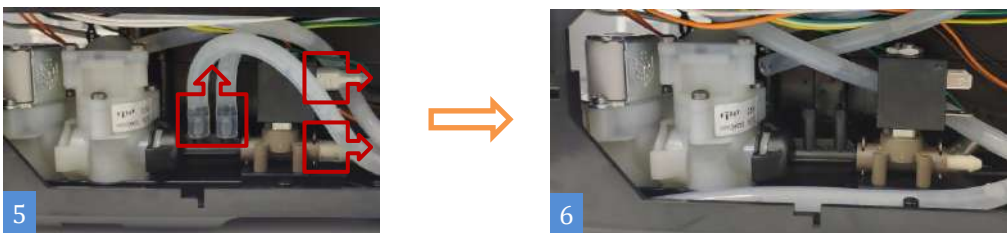

Step4: (Pic7) Push this position, and push water inlet valve to right.

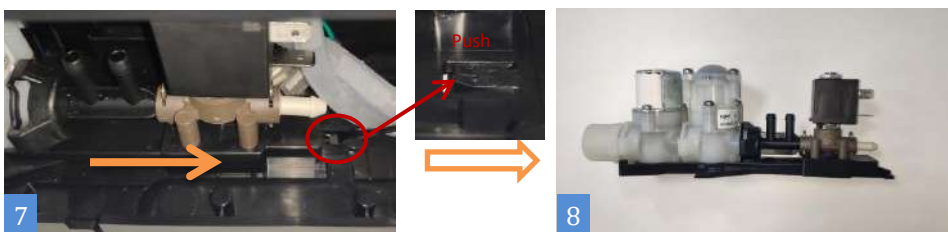

★ **Attention:**

- 1、 Unplug the coffee machine before doing this!

10.2.13 Disassemble Power PCB

Step: (Figure 1) First unplug all the power plugs on the power board, then (as shown in Figure 2) remove the five screws that secure the power board, and finally remove the power board.



★ Attention:

- 1、 Unplug the coffee machine before doing this !
- 2、 When pulling the cable plug, please press the buckle first and then pull the plug to prevent the terminal from being broken !

10.2.14 Disassemble Control Board

Step: (Figure 1) First unplug all the wiring plugs on the main control board, then (as shown in Figure 2) remove the four screws that fix the main control board, and finally remove the main control board.

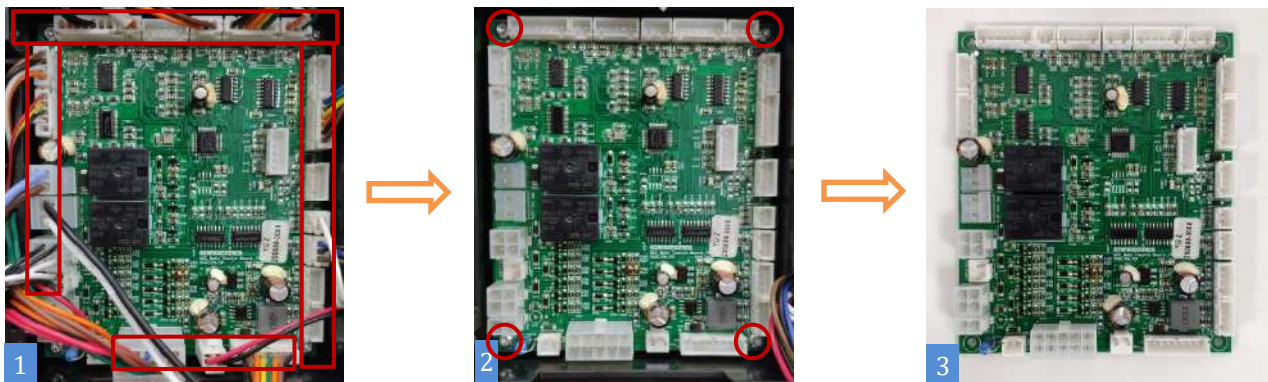

★ Attention:

- 1、 Unplug the coffee machine before doing this !
- 2、 When pulling the cable plug, please press the buckle first and then pull the plug to prevent the terminal from being broken !

10.2.15 Disassemble front panel group

Step1: (Pic.1) Pull out the three-way connector from the valve and unplug the milk tube, (Pic.2) Unplug the two water pipes;

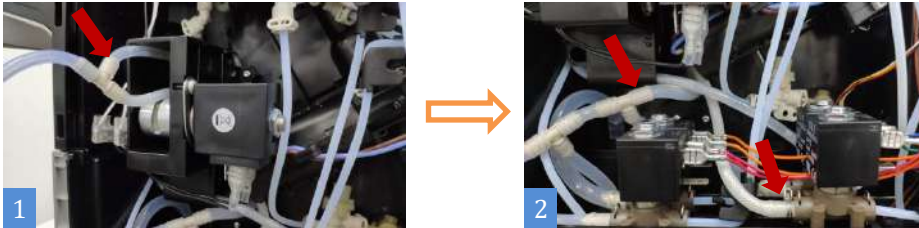

Step 2: Remove the screws with T10 (pic3, 4), Unplug (pic.4) coffee pipe;

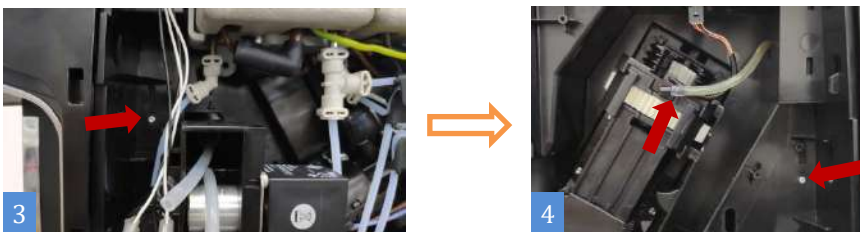

Step3: Remove the 4 screws with T10 (pic.5), then unplug the two plugs in the red box, pull out the entire assembly forcefully.

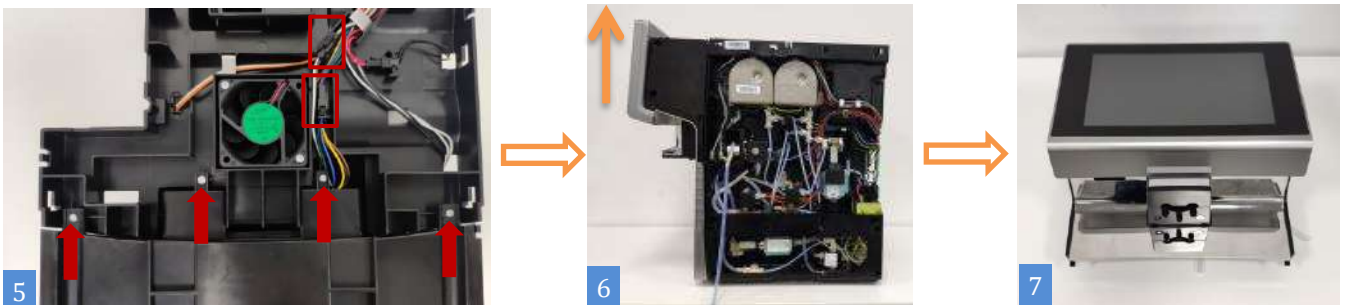

Step4: Remove the 4 screws with T10 (pic.8), pull out the plug, make the coffee outlet group is separated from the display group.



★ **Attention:**

1. The display is made of glass. Please take it lightly during the disassembly process to prevent the glass from breaking !

- 3、 There may be residual water in the pipe, please prepare a water container in advance!

11 Maintenance

11.1 Milk Frother Cleaning

11.1.1 Method for Disassembling Milk Frother

Step: Pinch the snap joints on both sides, pull down, then disassemble the milk frother.



★ **NOTE:**

1. Milk frother outlet may have hot water drops out, pay attention to be careful scald!

11.1.2 Method for Installing Milk Frother

Steps: press the milk froth in the connector and silicone parts pull out, take to the next tap rinse and then assembled back into the machine.

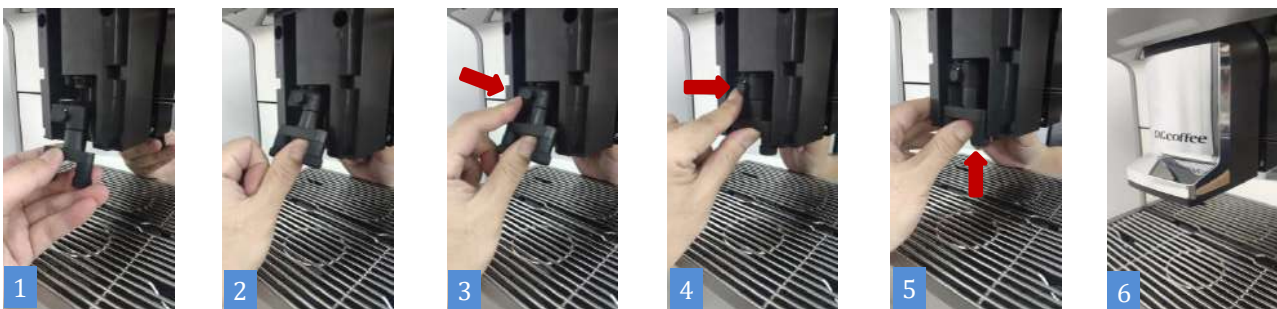

★ **NOTE:**

1. Please be sure to install the installation in place, otherwise it may cause, do not milk foam or milk foam device off the risk!

11.2 Milk Pipe Cleaning

11.2.1 Method of Milk Pipe Disassembling

Step 1: Move out the cover as the direction in Figure 1

Step2: Disassemble the milk pipe and disconnect to 3-way connector.

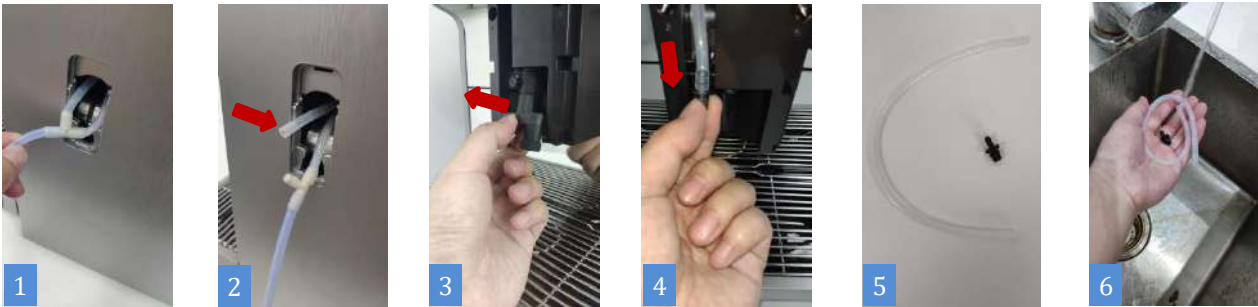

★ NOTE:

1. Do not break the Milk Pipe while assembling, or milk could not be sucked.

11.2.2 Method of Milk Pipe Connection

Step 1: Connect milk pipe to 3 Way Hose Connector, stick lock it into pinch valve. (Pic5)

Step 2: Lock milk pipe into the slot of cover, as the direction showed in (Figure 3) then assemble the cover into the hole, and make it fixed.



★ NOTE:

1. Do not break the Milk Pipe while assembling, or milk could not be sucked.

2. Do not squeeze the Milk Pipe narrowly when assembling, or milk could not be sucked.

12 Daily Use and Maintenance Considerations

1. Inside the bean hopper and powder hopper, please be sure not to add water;
2. During the operation of the coffee machine, please do not forcibly open the door of coffee machine, take out the Grounds box, waste water tray, water tank and other parts;
3. Only room temperature water can be poured into Water tank, hot water or ice water is forbidden;
4. It is recommended to use Medium Roasts or Medium-Dark to Dark Roasts beans. It is not recommended to use deep roasted or charcoal-roasted and oily coffee beans that are very large;
5. When the drink is out, do not place your hand at the outlet of the coffee machine.
6. When cleaning the cover of machine, please do not use brush or cleaning agent to prevent appearance damaging. Please wipe with a soft cloth dampened with water.
7. Please do not exceed the MAX line. If there is no MAX line, it can be filled over 80%.
8. During coffee making, self-checking, self-cleaning please do not cut off the power.
9. Please adjust the height of the coffee cup according to the height of the coffee cup, avoid drinks splashing.
10. Please follow the correct switching off steps: please tap the Power Off button, the coffee machine will automatically into the rinse, rinse after the completion of the screen goes out, and then press the coffee machine power switch off. Please do not pull the power plug directly.
11. After one day using, please empty coffee grounds and waste water of the machine and clean the machine. To ensure the quality of the coffee, we recommend daily water tank clean and water exchanging.
12. If linked with tap water, drink making is forbidden while the water supply stopped.

Dr.coffee 咖博士

Suzhou Dr. Coffee System Technology Co., Ltd

Address: No.3 Building, No.55 Taishan Road, New
District, Suzhou, Jiangsu, China

Post Code: 215163

Tel: 400-897-7711

Website: www.dr-coffee.com